



## Workshop Manual

up! 2012 ➤

up! 2017 ➤

up! 2020 ➤

### Vehicle-specific paint information

Edition 10.2019





## List of Workshop Manual Repair Groups

### Repair Group

00 - Technical data



Technical information should always be available to the foremen and mechanics, because their careful and constant adherence to the instructions is essential to ensure vehicle road-worthiness and safety. In addition, the normal basic safety precautions for working on motor vehicles must, as a matter of course, be observed.

All rights reserved.  
No reproduction without prior agreement from publisher.



## Contents

<b>00 - Technical data</b>	<b>1</b>
<b>1 Explanation of symbols</b>	<b>1</b>
1.1 Sanding	1
1.2 Seam sealing	1
1.3 Cavity sealing	3
<b>2 Paintwork structure</b>	<b>4</b>
2.1 Structure of factory finish, cathodic dip primer	4
2.2 Structure of factory finish, undercoat	6
2.3 Structure of factory finish, base coat	8
2.4 Structure of factory finish, clear coat	16
<b>3 Areas exposed to stone chipping</b>	<b>24</b>
3.1 Body areas exposed to stone chipping	24
<b>4 Masked sectors</b>	<b>29</b>
4.1 Masking areas, front body	29
4.2 Masking areas, rear body	38
4.3 Masking areas Cross UP	46
<b>5 Seam sealing</b>	<b>47</b>
5.1 Seam seals, front body	47
5.2 Seam seals, centre body	55
5.3 Seam seals, rear body	63
<b>6 Underseal</b>	<b>68</b>
6.1 Underseal, body overview with differing layer thickness	68
6.2 Underseal, protected areas	70
<b>7 Cavity sealing</b>	<b>78</b>
7.1 Cavity sealing, body - overview	78
7.2 Cavity sealing, front body	78
7.3 Cavity sealing, body – centre	79
7.4 Cavity sealing, rear body	81
<b>8 Contrasting colours</b>	<b>84</b>
8.1 Contrasting colours »Cross«up	84
8.2 Contrasting colours »Cheer«up	85
8.3 Contrasting colours »Groove«up	86
8.4 Contrasting colours »Cup«up	87
8.5 Contrasting colours »Street«up	88
8.6 Contrasting colours, roof	89





## 00 – Technical data

### 1 Explanation of symbols

(VRL013519; Edition 10.2019)

⇒ [“1.1 Sanding”, page 1](#)

⇒ [“1.2 Seam sealing”, page 1](#)

⇒ [“1.3 Cavity sealing”, page 3](#)

#### 1.1 Sanding

**Avoid sanding through to substrate**

- It is recommended to carefully sand the marked area by hand to avoid “sanding through” the cathodic dip primer.



#### 1.2 Seam sealing

**Sealing**

- Apply sealant.

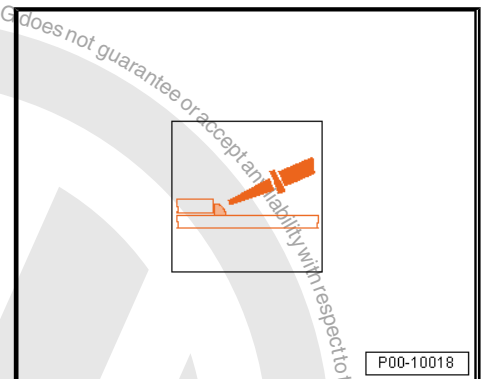

**Fine seam sealing**

- Fine seam seals require that the sealant extend at least 3 mm from the seam in each direction and must have a thickness of 1.5 mm to 2 mm.

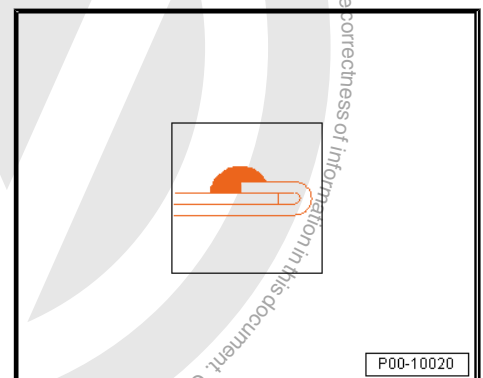



### Coarse seam sealing

- Coarse seam seals require that the sealant be applied at least 8 mm wide and 2 mm high.

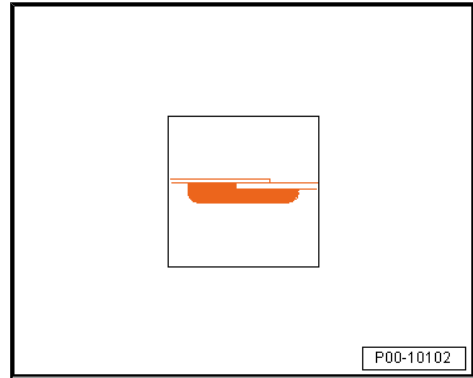

### Smoothing seals

- Sealant in the marked areas must be smoothed following application.



#### Note

*When smoothing the sealant seam, ensure that the sheet metal edges which are to be protected are not exposed. The metal must be covered with a sufficiently thick layer of PVC.*

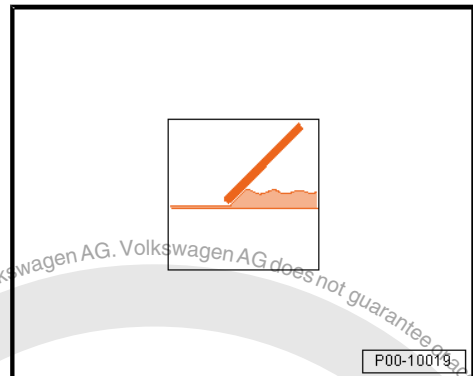

### Brushing seals

- Sealant in the marked areas must be brushed following application.



#### Note

*When brushing the sealant seam, ensure that the sheet metal edges which are to be protected are not exposed and that the metal is covered with a sufficiently thick layer of PVC.*

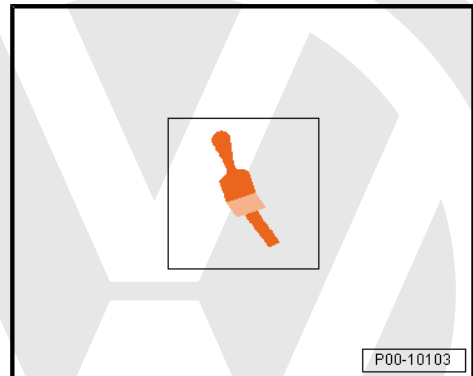

### Sealing the folded seam groove

- The marked areas must be closed following application of sealant to the folded seam groove.



#### Note

*When brushing the sealant seam, ensure that the sheet metal edges which are to be protected are not exposed. The metal must be covered with a sufficiently thick layer of PVC so that the groove in the folded seam remains closed.*

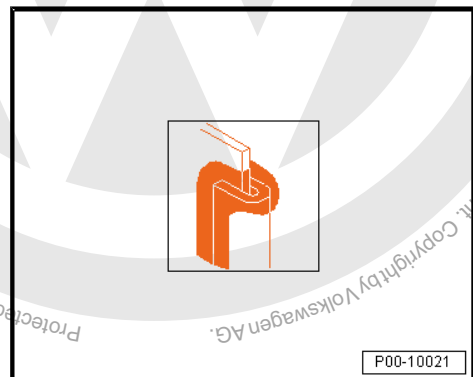



## 1.3 Cavity sealing

### Sealing cavities

- The marked areas must be sealed following body repair.



Protected by copyright. Copying for private or commercial purposes, in part or in whole, is not permitted unless authorised by Volkswagen AG. Volkswagen AG does not guarantee or accept any liability with respect to the correctness of information in this document. Copyright by Volkswagen AG.



## 2 Paintwork structure

⇒ ["2.1 Structure of factory finish, cathodic dip primer", page 4](#)

⇒ ["2.2 Structure of factory finish, undercoat", page 6](#)

⇒ ["2.3 Structure of factory finish, base coat", page 8](#)

⇒ ["2.4 Structure of factory finish, clear coat", page 16](#)

### 2.1 Structure of factory finish, cathodic dip primer

Cathodic dip primer, 2-door

- Cathodic dip primer



Note

*The body in white is phosphated beneath the cathodic dip primer.*

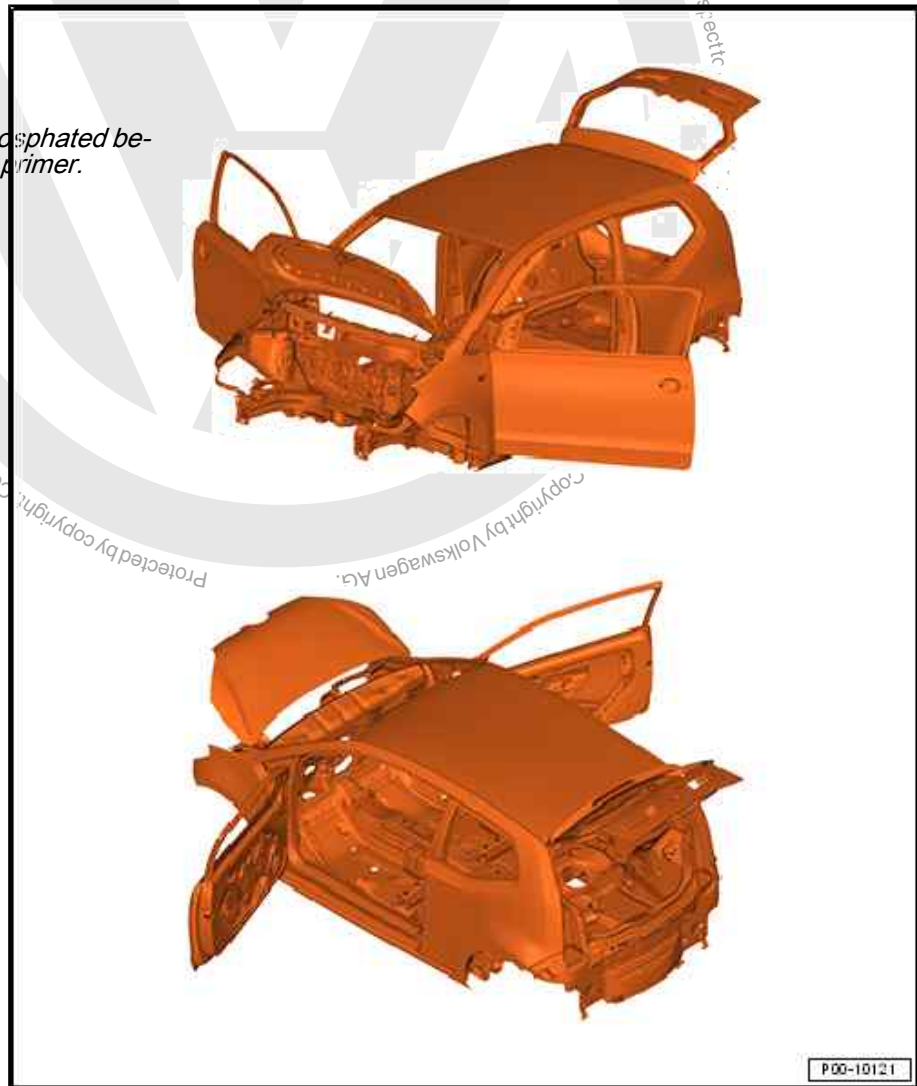

Cathodic dip primer, 4-door





- Cathodic dip primer



Note

*The body in white is phosphated beneath the cathodic dip primer.*

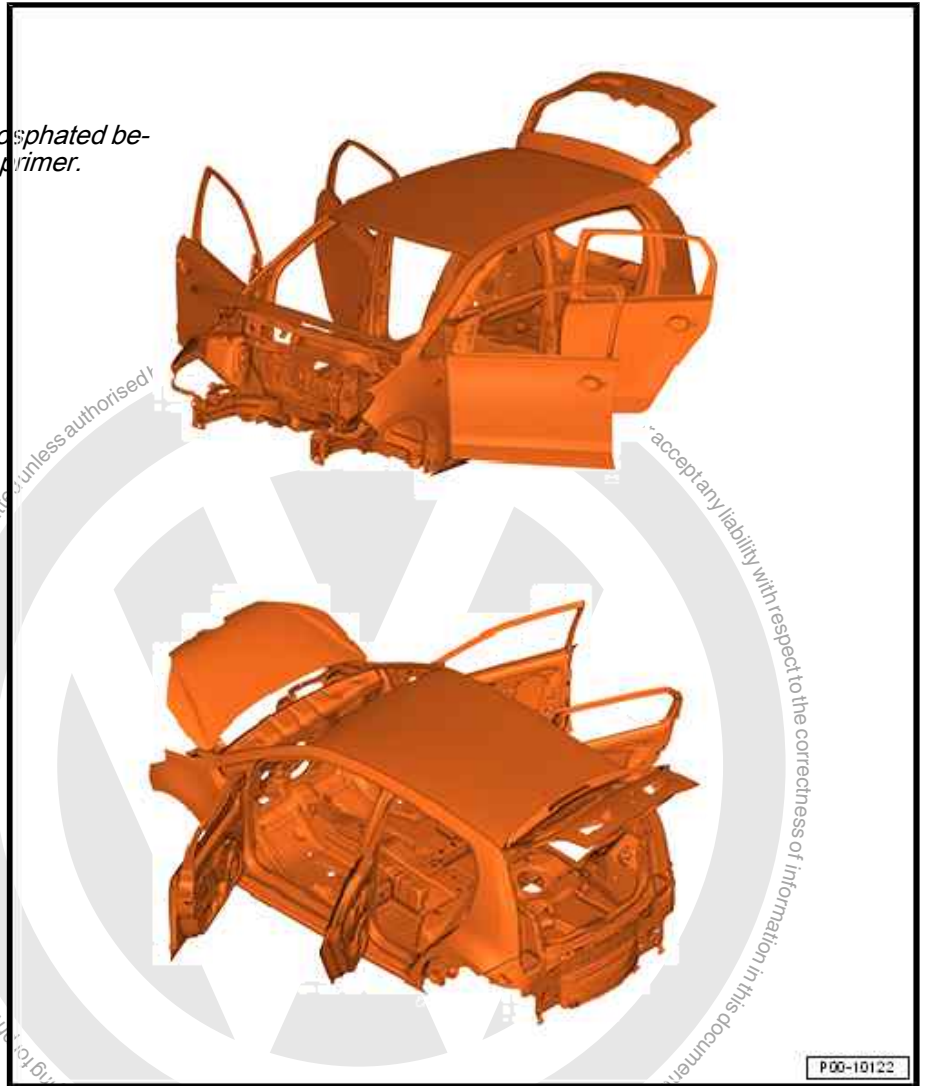



## 2.2 Structure of factory finish, undercoat

### Undercoat, 2-door model

#### - Undercoat

- The areas of the body shown in colour are undercoated only for certain paint colours.



#### Note

*The undercoat is applied only in the factory. In the event of repainting repair, these parts and areas are excluded.*

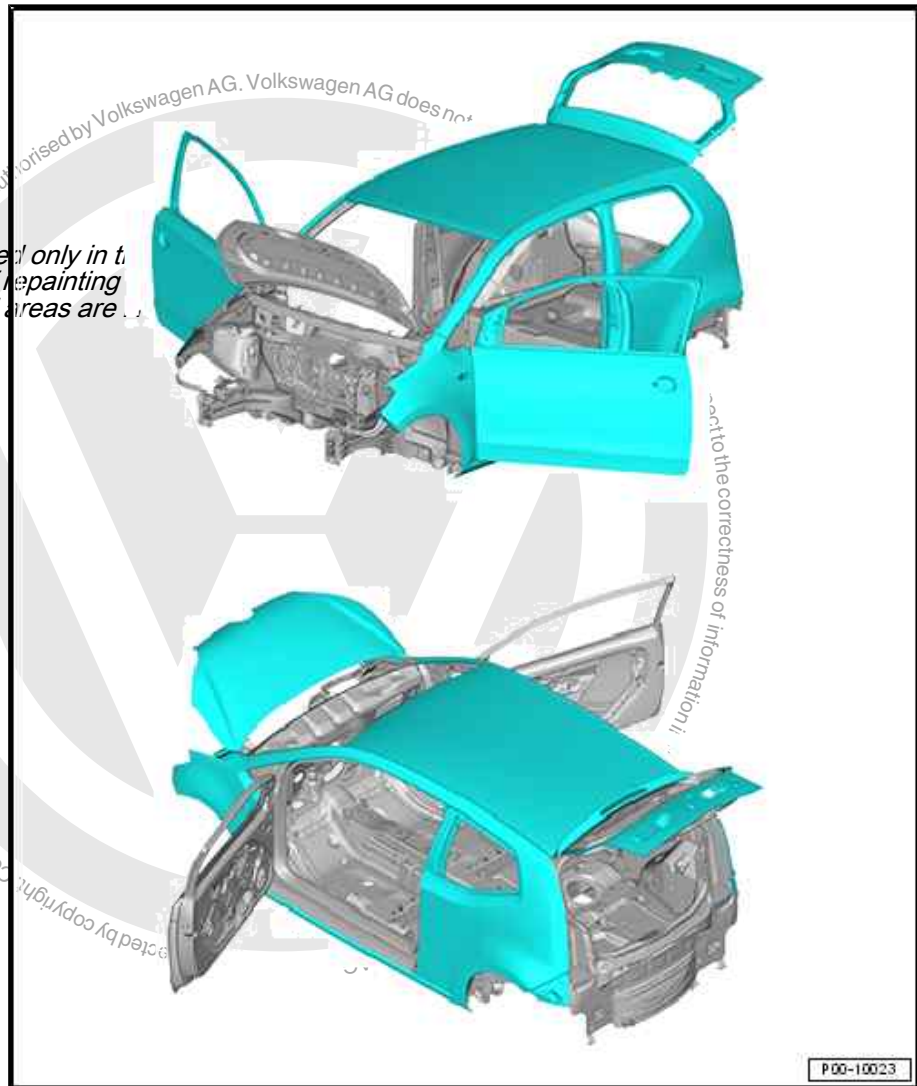

### Undercoat, 4-door model



### - Undercoat

- The areas of the body shown in colour are undercoated only for certain paint colours.



#### Note

*The undercoat is applied only in the factory. In the event of repainting or repair, these parts and areas are filled.*

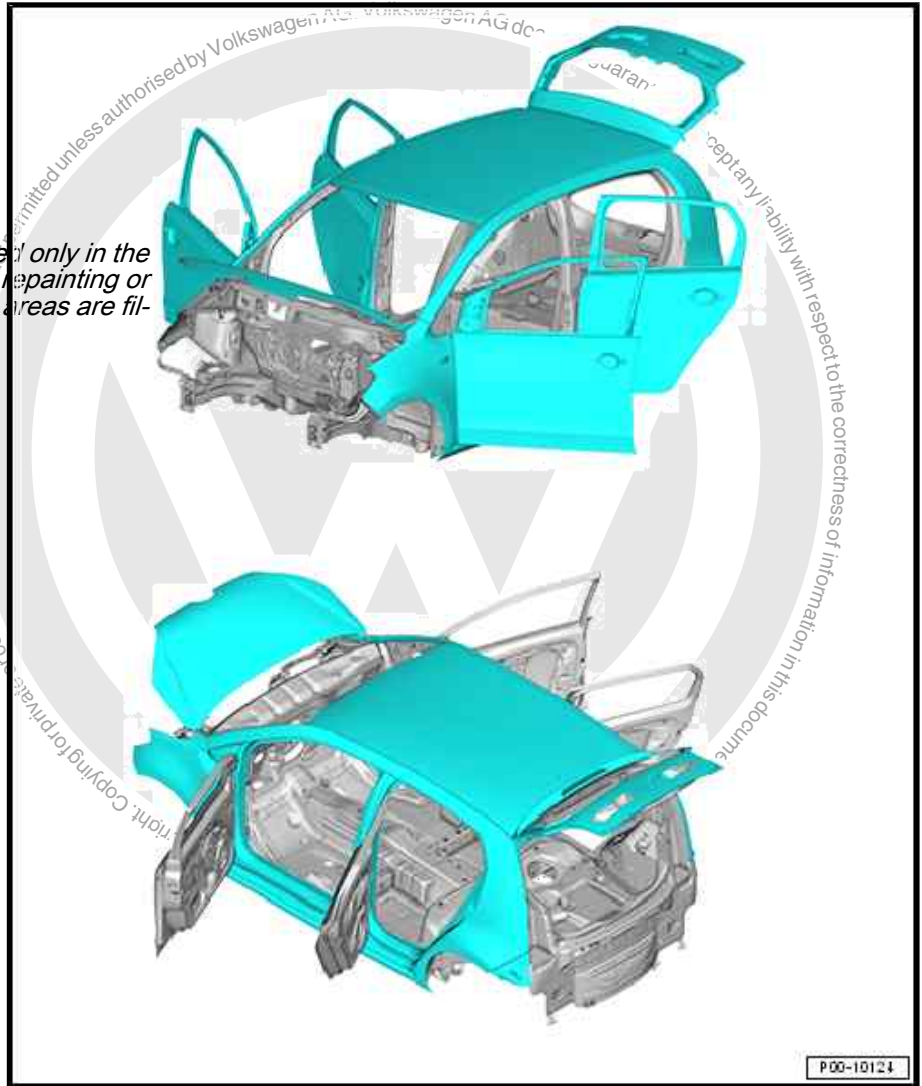

P00-10124



## 2.3 Structure of factory finish, base coat

### Base coat, 2-door model

#### - Base coat

- Only the coloured areas of the body receive a base coat.

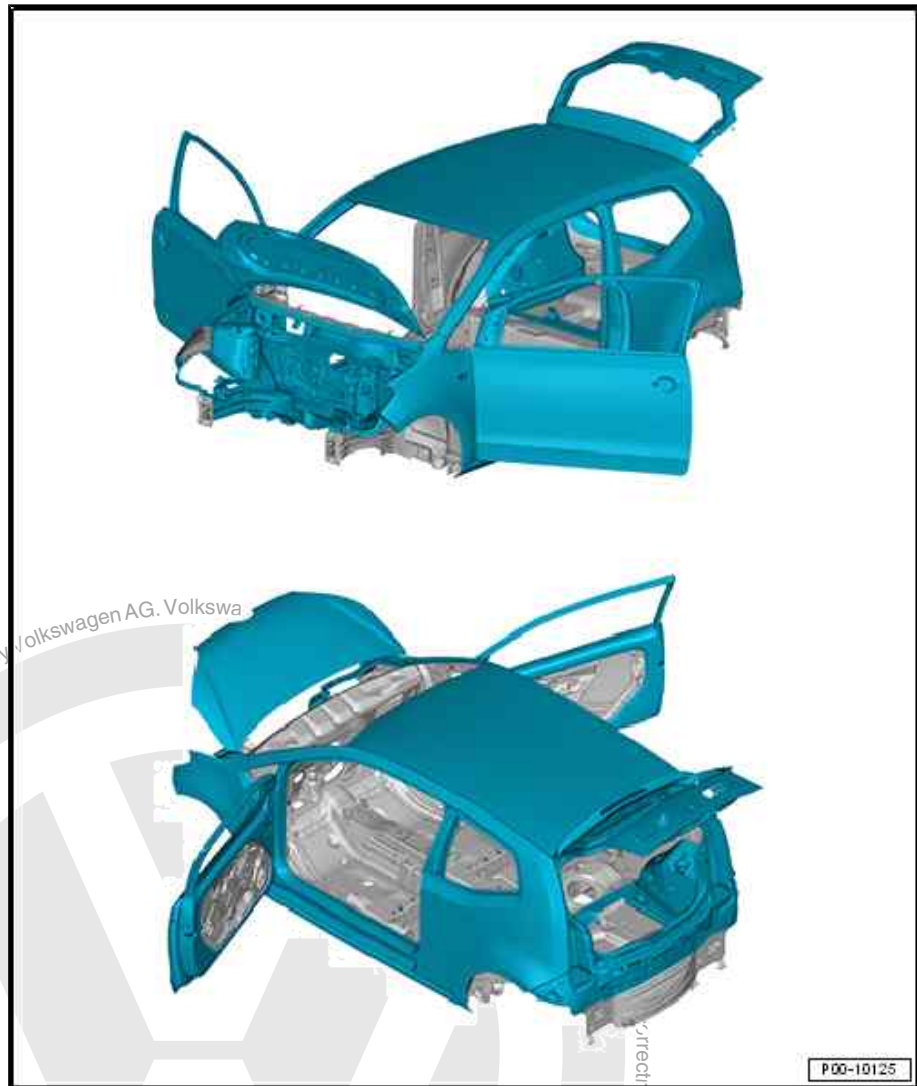

### Base coat, 4-door model



**- Base coat**

- Only the coloured areas of the body receive a base coat.

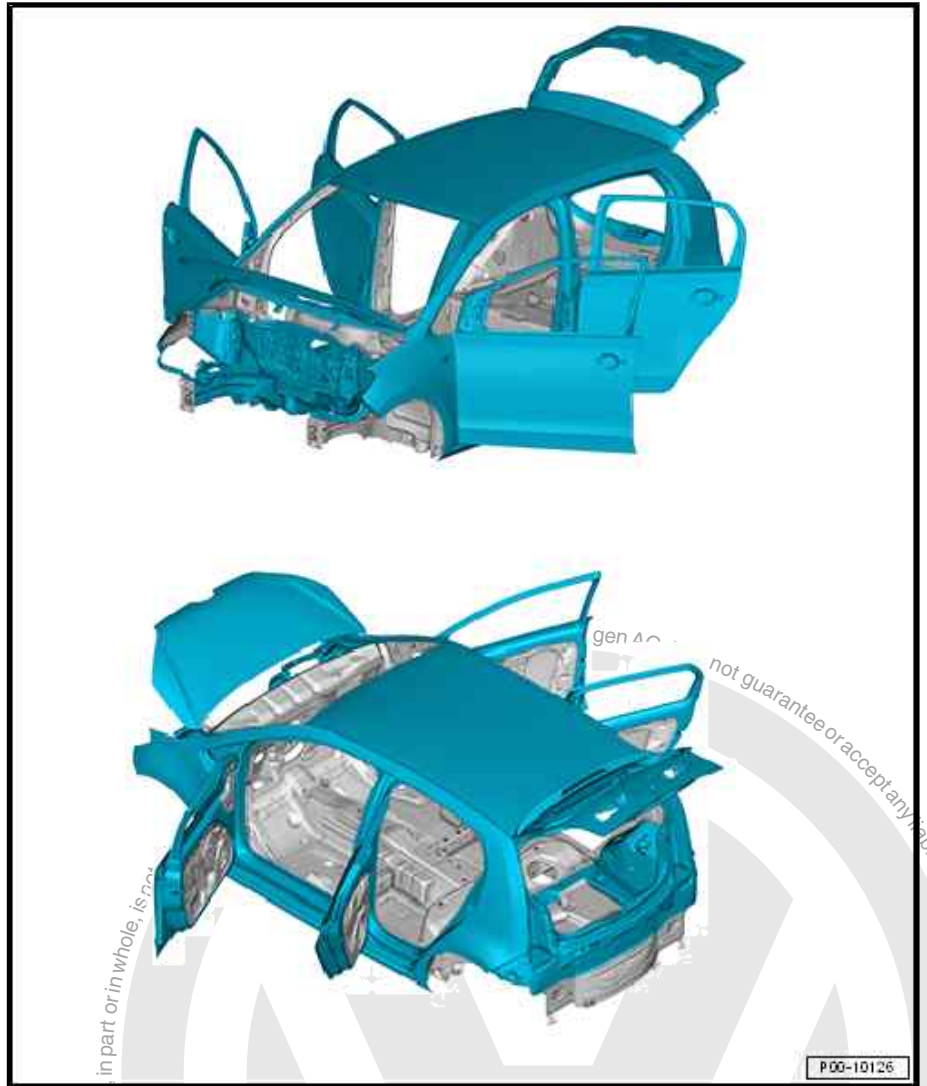

**Base coat, front body**



### - Base coat

- Only the coloured areas of the body receive a base coat.

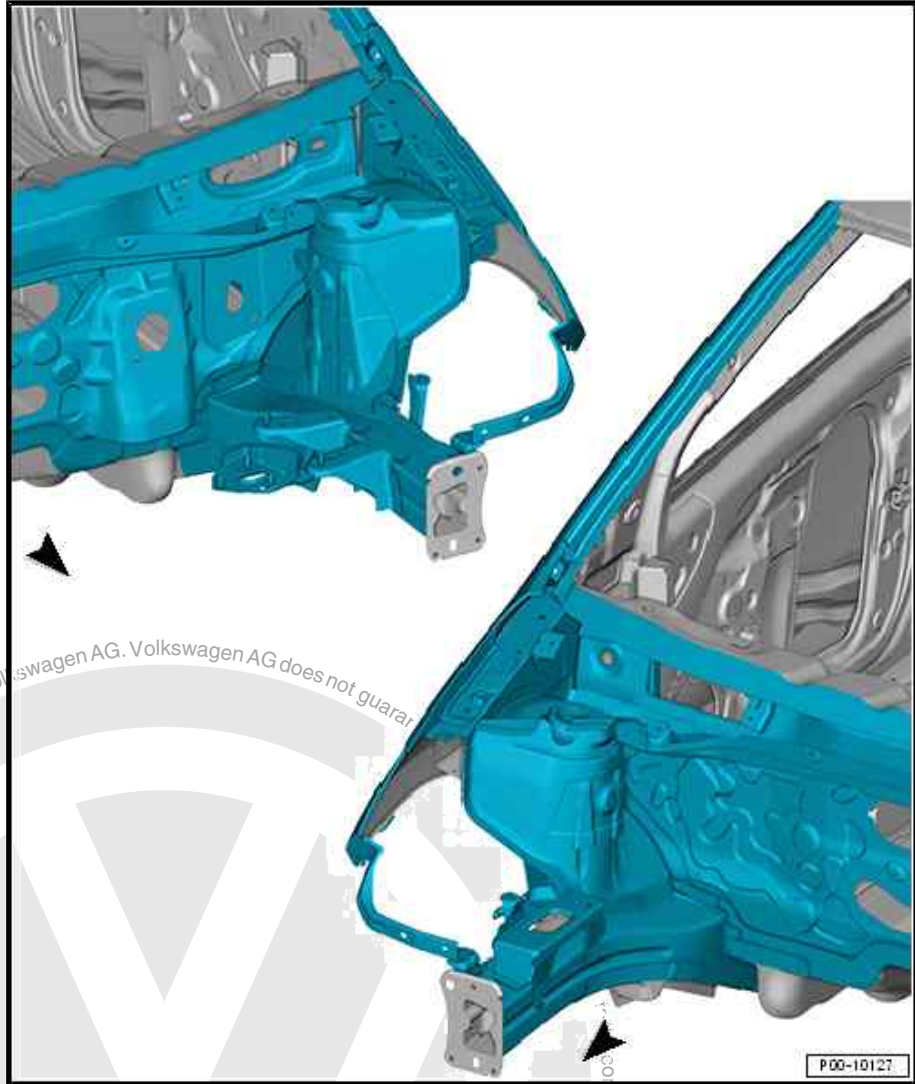

### Base coat, luggage compartment

Illustration shows left side. The right side is the mirror image.



**- Base coat**

- ❑ Only the coloured areas of the body receive a base coat.

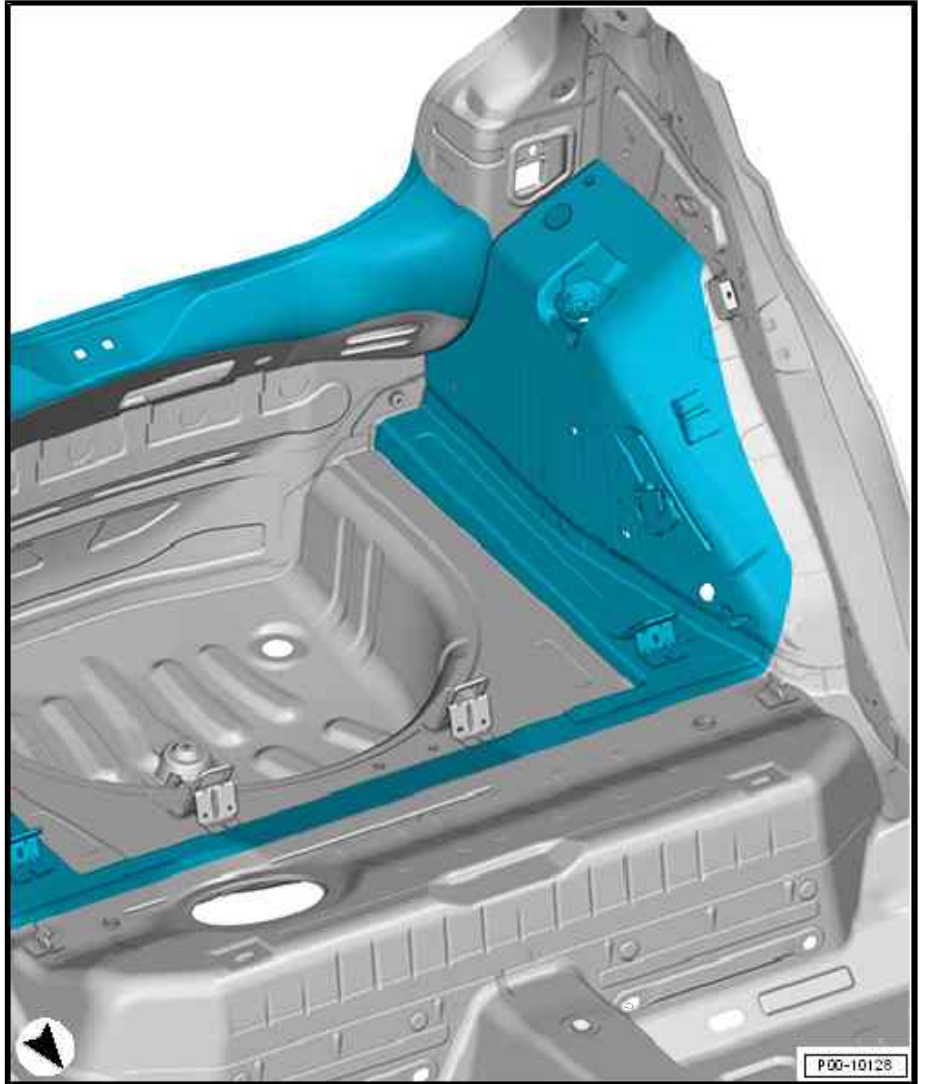

**Base coat, bonnet and rear lid**





**- Base coat**

- Only the coloured areas of the body receive a base coat.

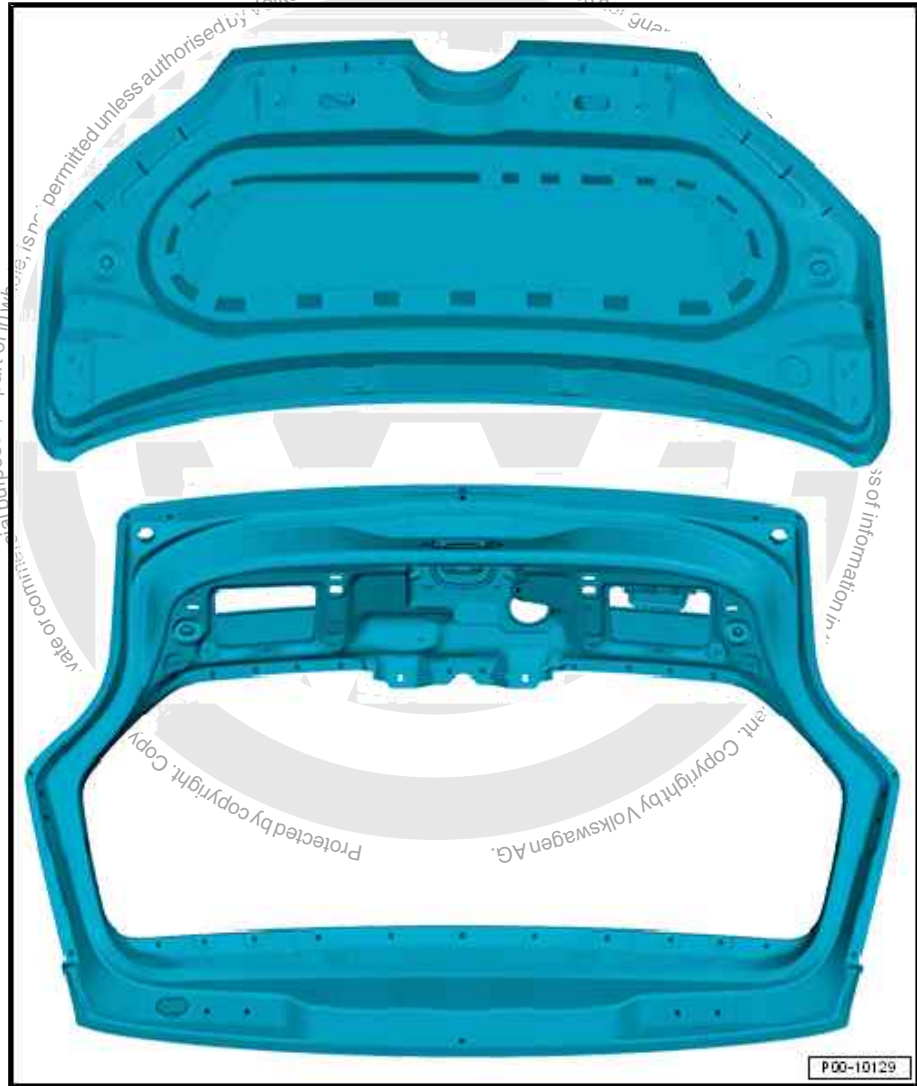

**Base coat, door of 2-door**

Illustration shows left side. The right side is the mirror image.





**- Base coat**

- ❑ Only the coloured areas of the body receive a base coat.



**Base coat, front door of 4-door**

Illustration shows left side. The right side is the mirror image.



**- Base coat**

- Only the coloured areas of the body receive a base coat.



**Base coat, rear door of 4-door**

Illustration shows left side. The right side is the mirror image.



**- Base coat**

- Only the coloured areas of the body receive a base coat.



Protected by copyright. Copying for private or commercial purposes, in part or in whole, is not permitted unless authorised by Volkswagen AG. Liability with respect to the correctness of information in this document. Copyright by Volkswagen AG.



## 2.4 Structure of factory finish, clear coat

### Clear coat, 2-door model

#### - Clear coat

- Only the coloured areas of the body receive a clear coat.

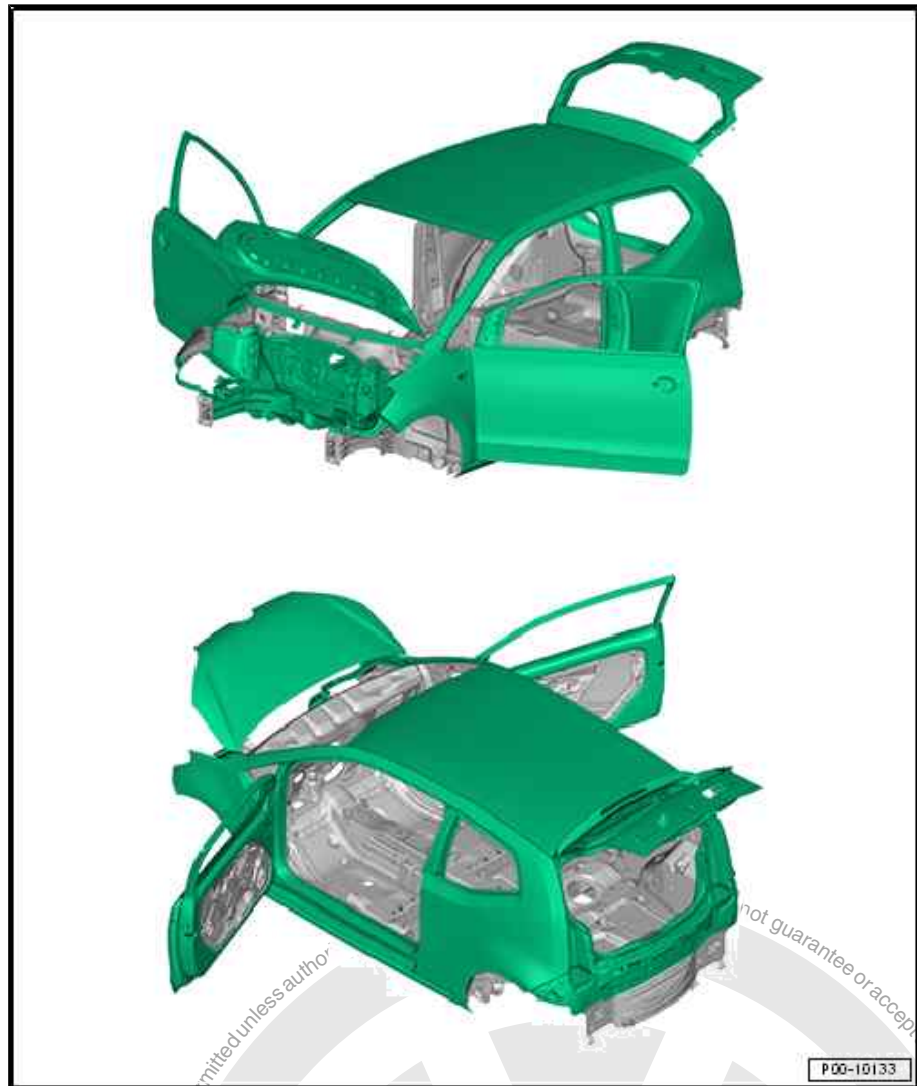

### Clear coat, 4-door model



- Clear coat

- Only the coloured areas of the body receive a clear coat.

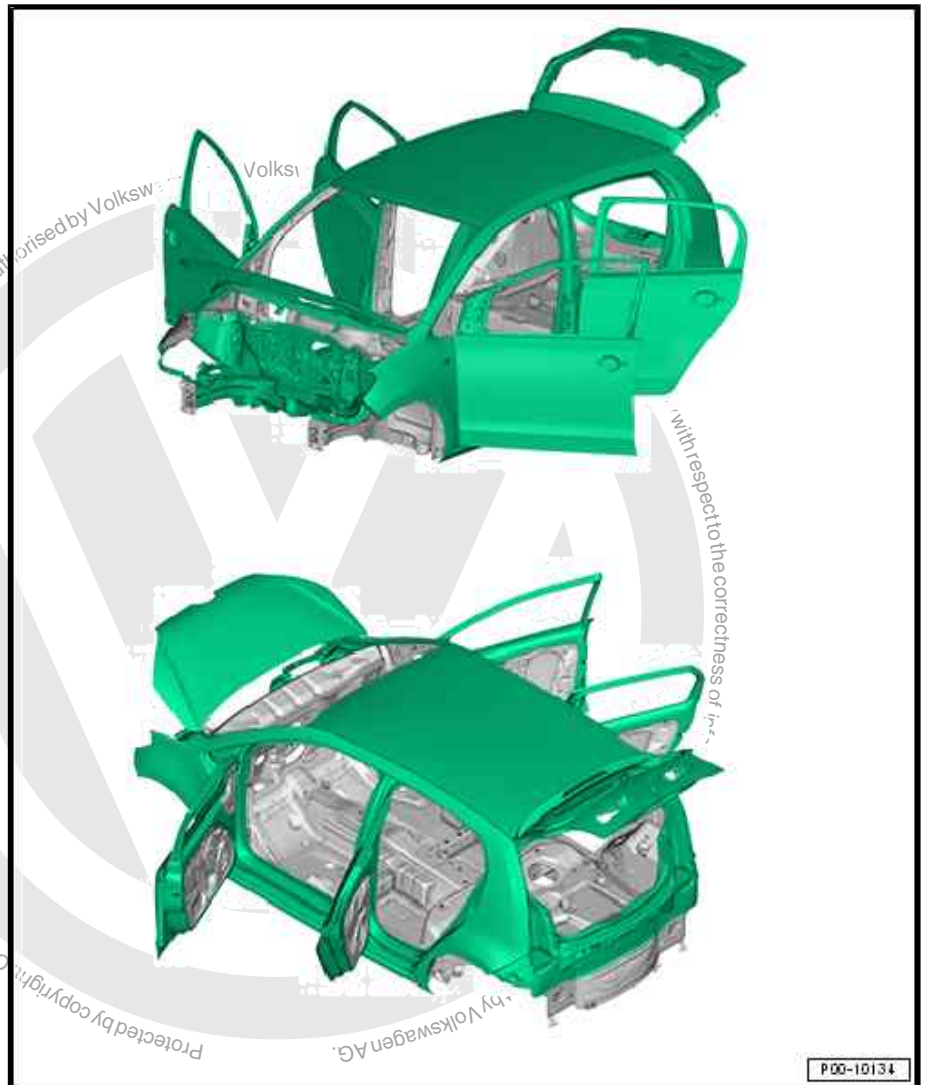

Clear coat, front body



- Clear coat

- Only the coloured areas of the body receive a clear coat.

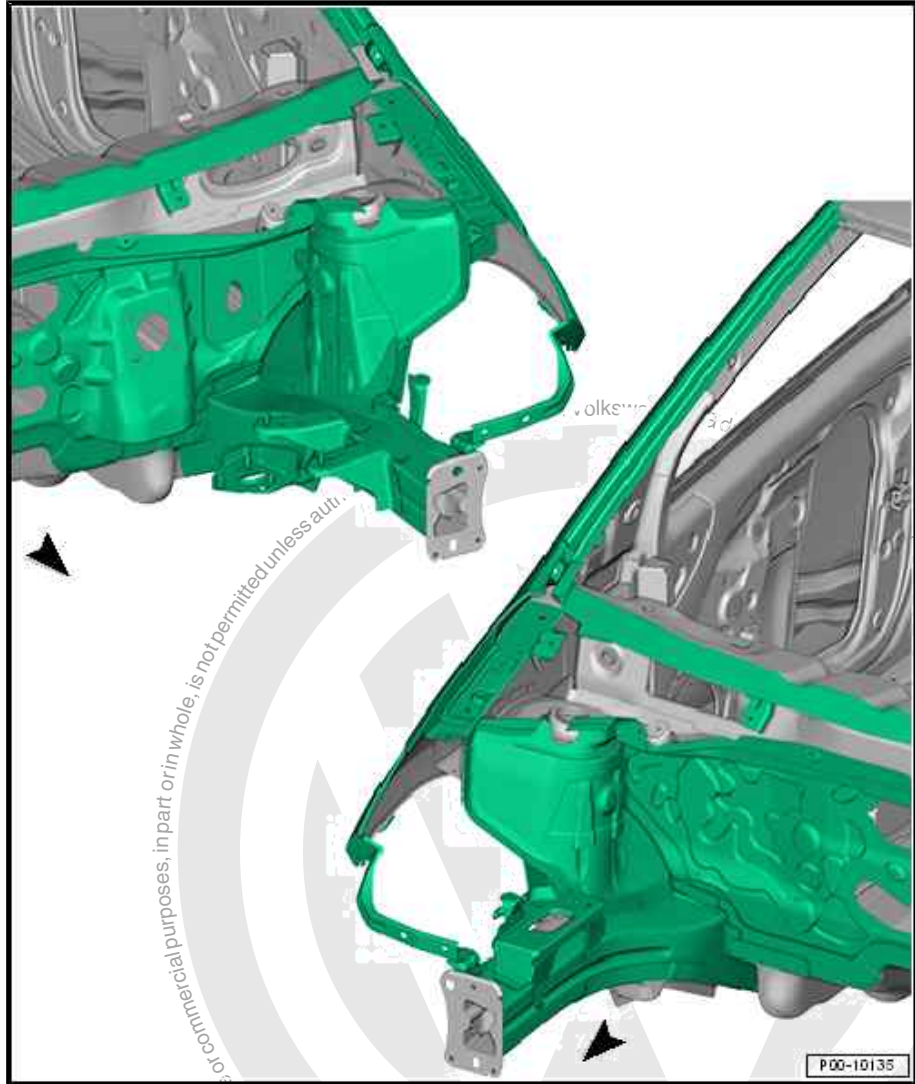

Clear coat, luggage compartment



- Clear coat

- ❑ Only the coloured areas of the body receive a clear coat.

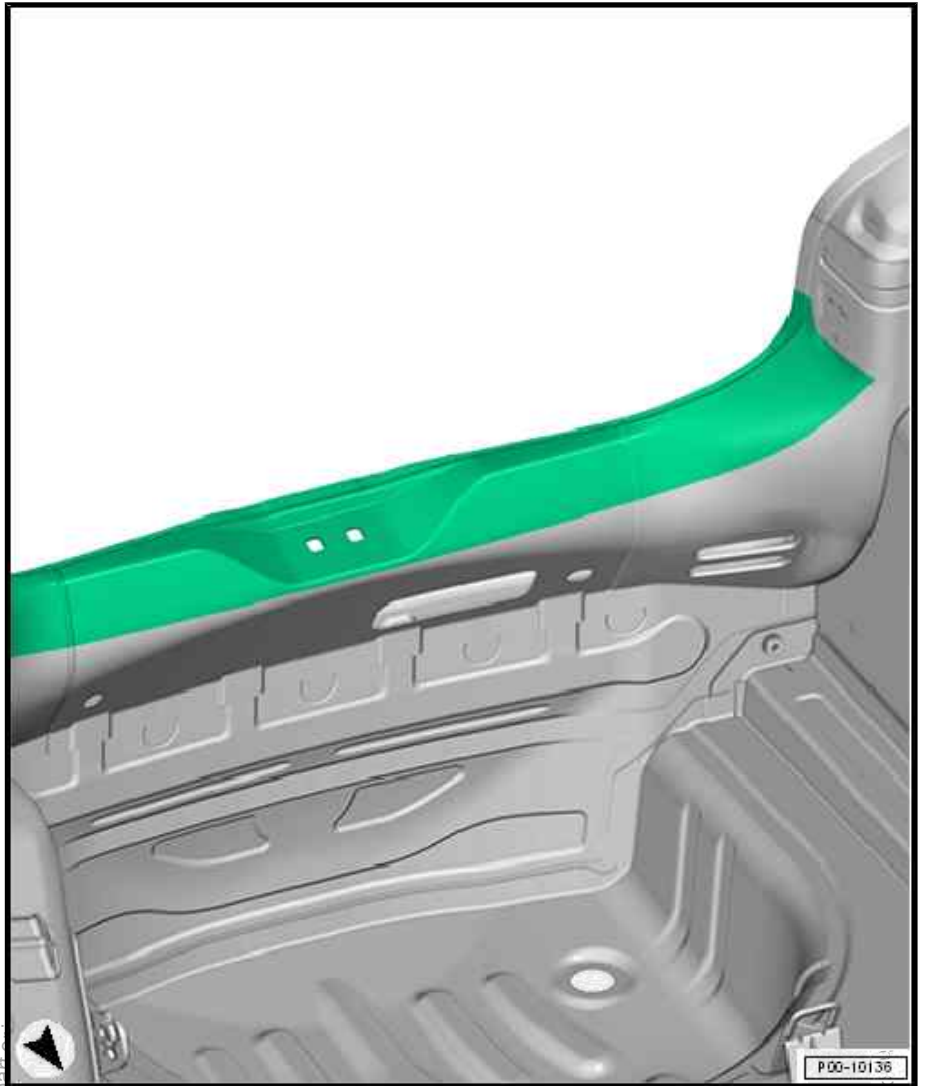

Clear coat, bonnet and rear lid

Protected by copyright. Copying for private or commercial purposes, in part or in full, is prohibited. Correctness of information in this document. Copyright by Volkswagen AG.



- Clear coat

- Only the coloured areas of the body receive a clear coat.

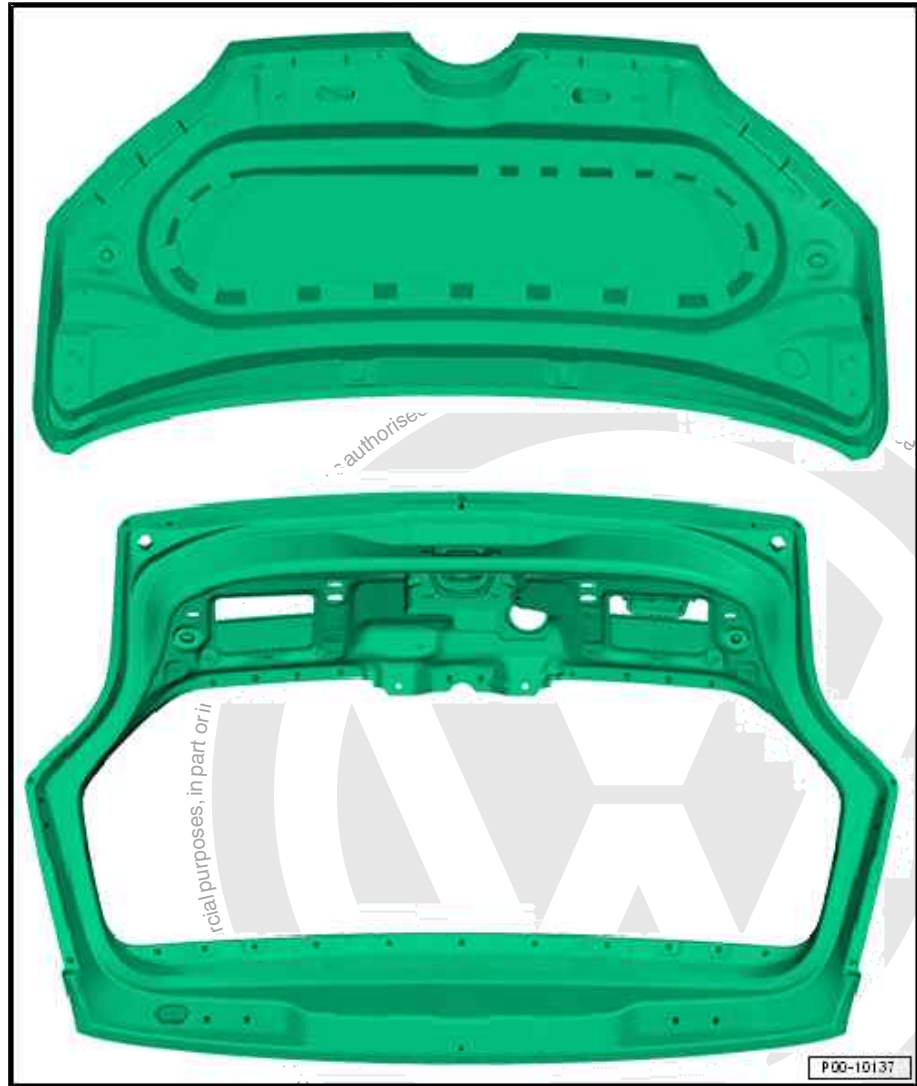

Clear coat, door of 2-door

Illustration shows left side. The right side is the mirror image.





- Clear coat

- ❑ Only the coloured areas of the body receive a clear coat.



**Clear coat, front door of 4-door**

Illustration shows left side. The right side is the mirror image.



- Clear coat

- Only the coloured areas of the body receive a clear coat.



**Clear coat, rear door of 4-door**

Illustration shows left side. The right side is the mirror image.



- Clear coat

- Only the coloured areas of the body receive a clear coat.

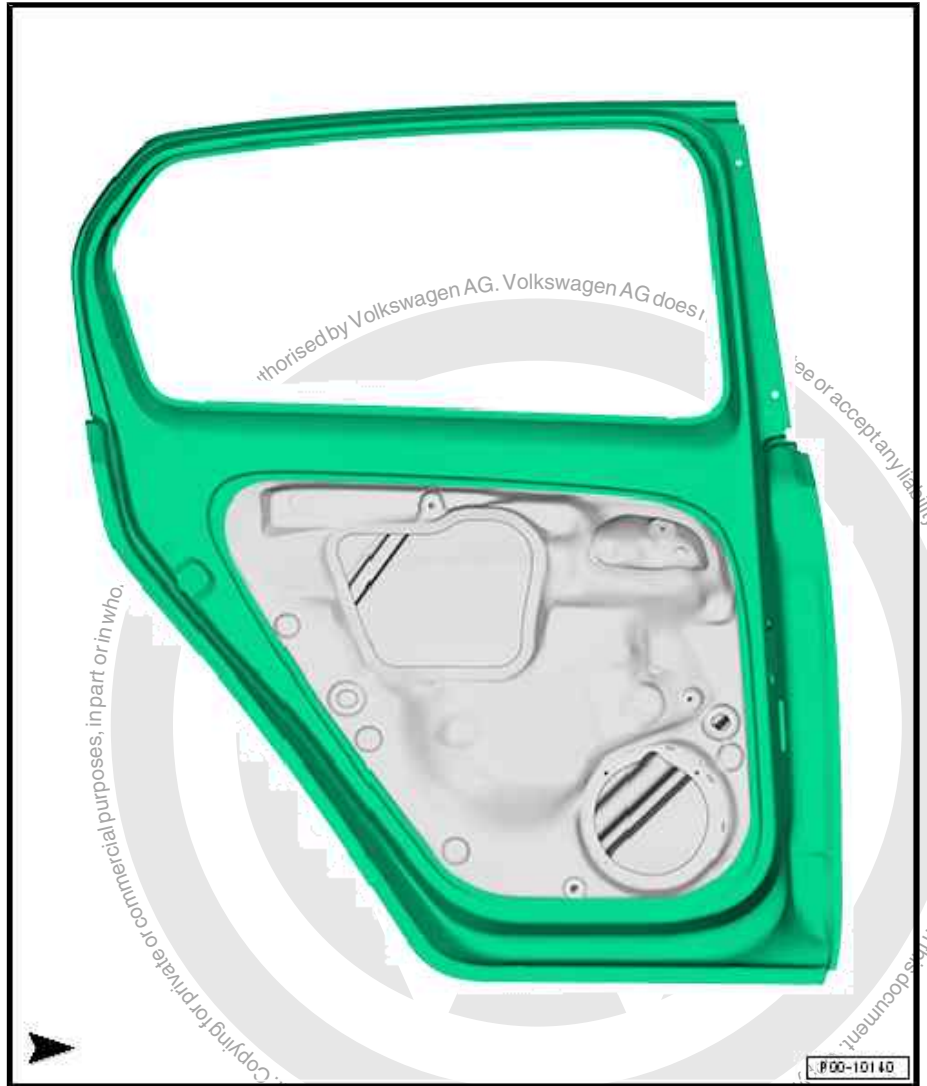



### 3 Areas exposed to stone chipping

⇒ "3.1 Body areas exposed to stone chipping", page 24

#### 3.1 Body areas exposed to stone chipping

Body overview, 2-door models up to model year 2016

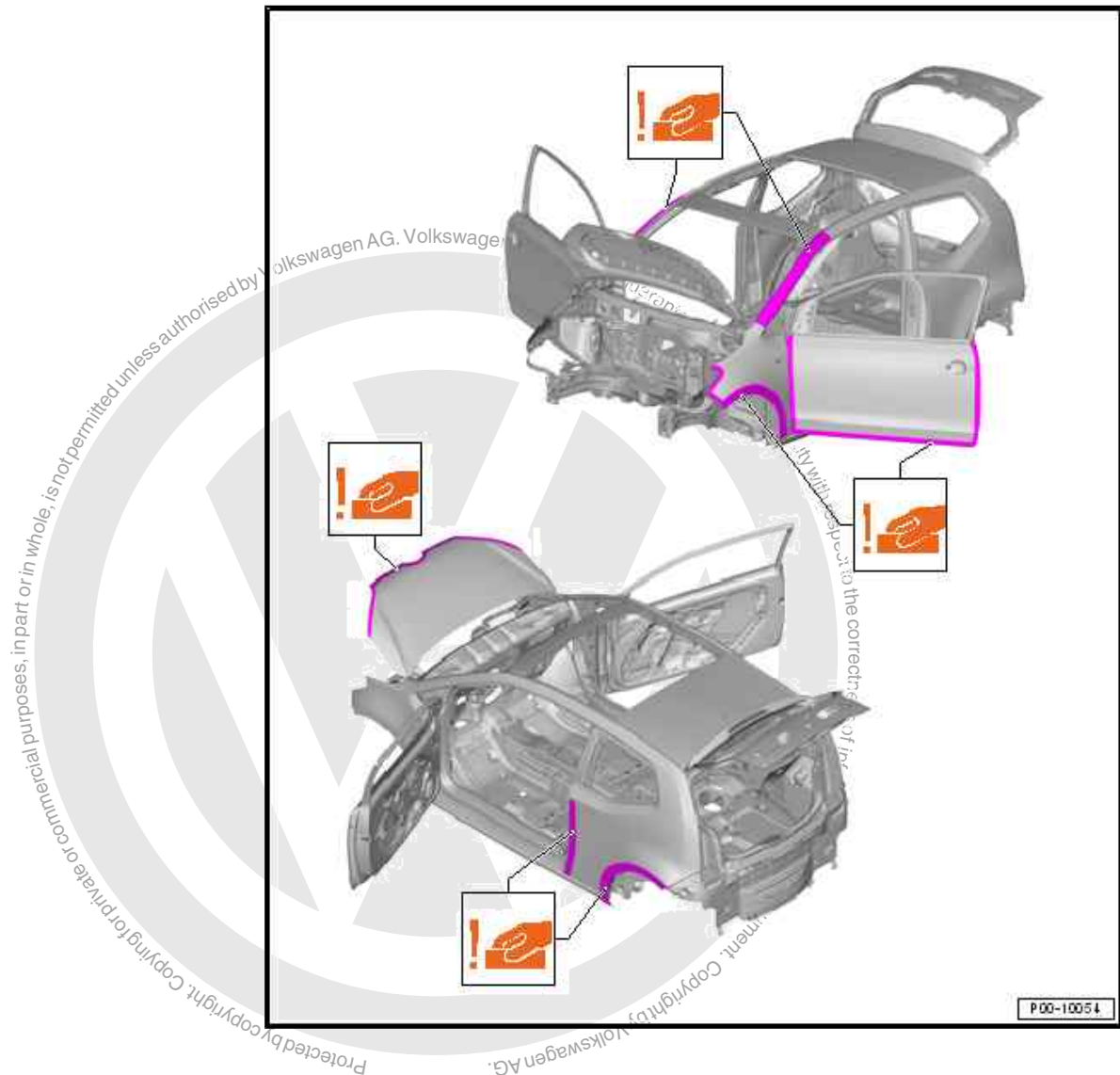

#### Note

- ◆ *The marked areas are exposed to stone chipping.*
  - ◆ *When sanding these areas, note thickness of the paint structure and avoid sanding through. This is the only way to ensure long-term corrosion protection.*
  - ◆ *Any areas that are sanded through must be treated according to ⇒ General paint information; Rep. gr. 00; General notes; Work instructions for underseal and anti-chip coating .*
- It is recommended to carefully sand the marked area by hand to avoid "sanding through" the cathodic dip primer.

Body overview, 2-door models as of model year 2017

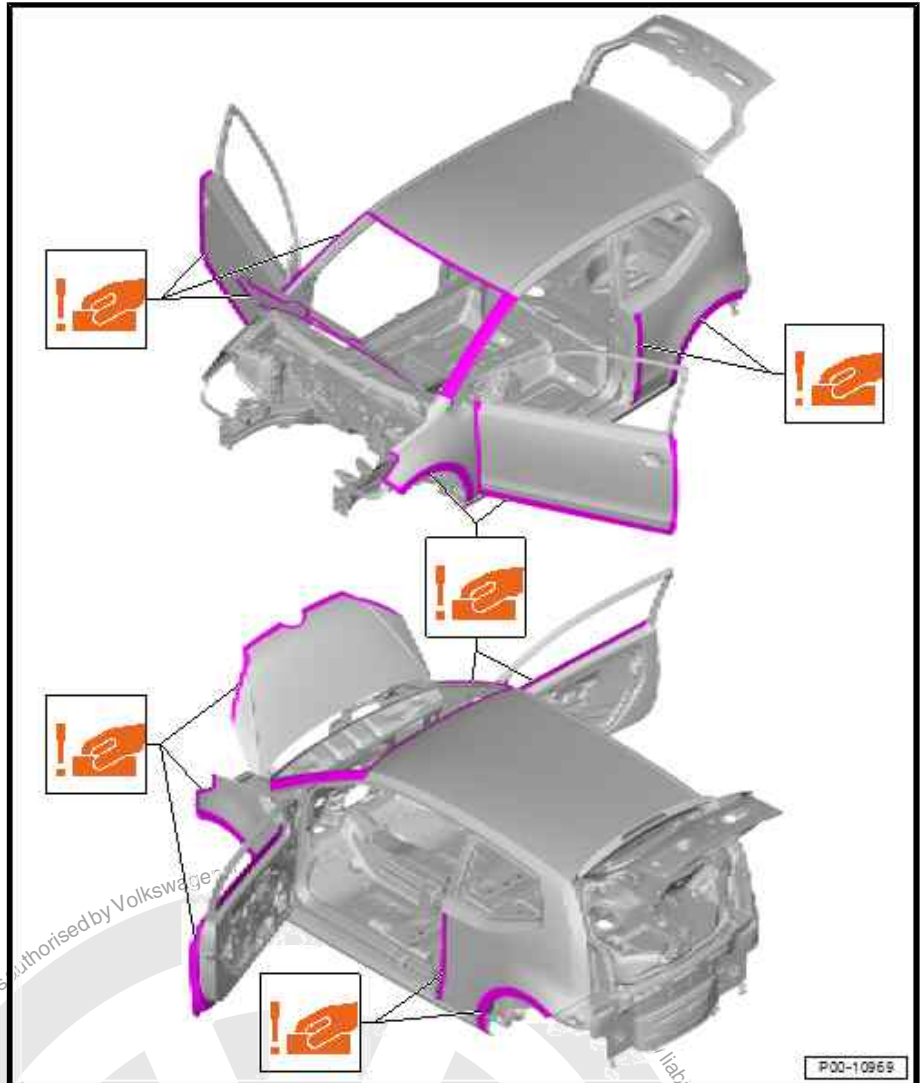

**i** Note

- ◆ *The marked areas are exposed to stone chipping.*
  - ◆ *When sanding these areas, note thickness of the paint structure and avoid sanding through. This is the only way to ensure long-term corrosion protection.*
  - ◆ *Any areas that are sanded through must be treated according to ⇒ General paint information; Rep. gr. 00 ; General notes; Work instructions for underseal and anti-chip coating .*
- It is recommended to carefully sand the marked area by hand to avoid “sanding through” the cathodic dip primer.

**Body overview, 4-door models up to model year 2016**

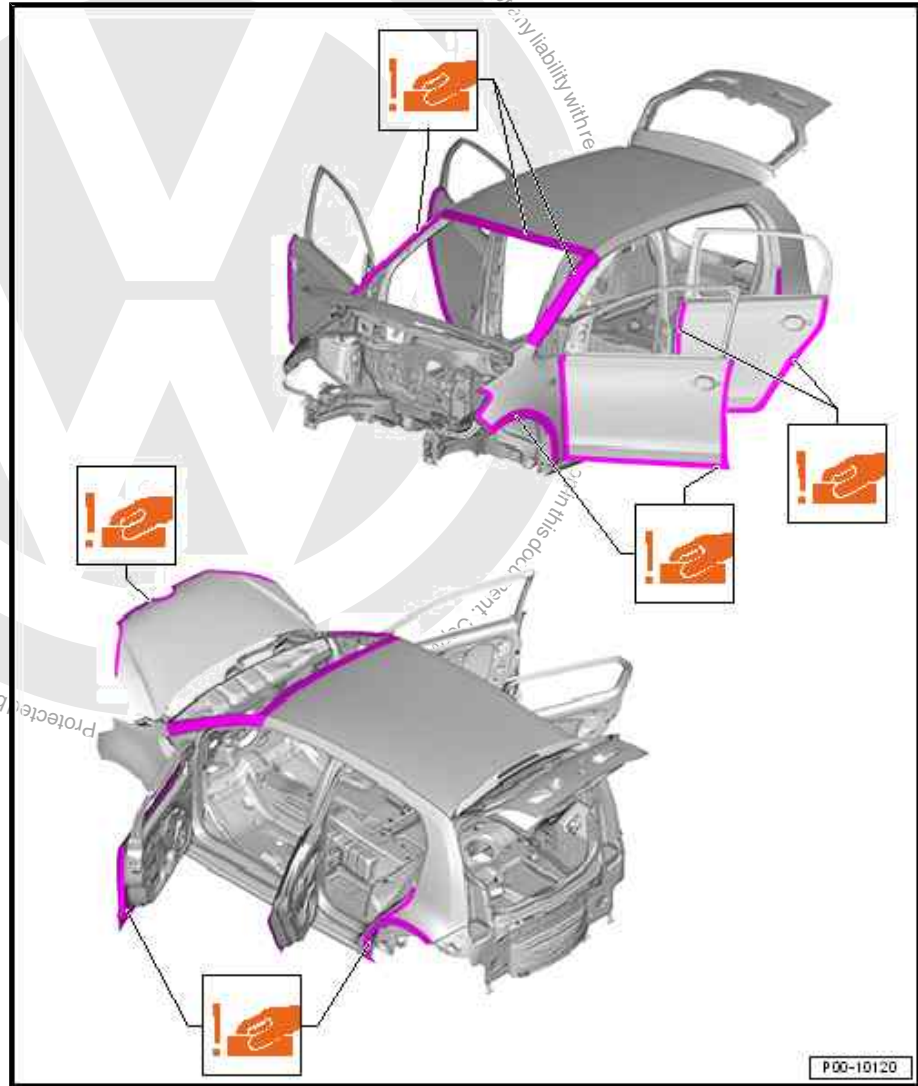

#### Note

- ◆ *The marked areas are exposed to stone chipping.*
  - ◆ *When sanding these areas, note thickness of the paint structure and avoid sanding through. This is the only way to ensure long-term corrosion protection.*
  - ◆ *Any areas that are sanded through must be treated according to ⇒ General paint information; Rep. gr. 00; General notes; Work instructions for underseal and anti-chip coating .*
- It is recommended to carefully sand the marked area by hand to avoid “sanding through” the cathodic dip primer.

**Body overview, 4-door models as of model year 2017**

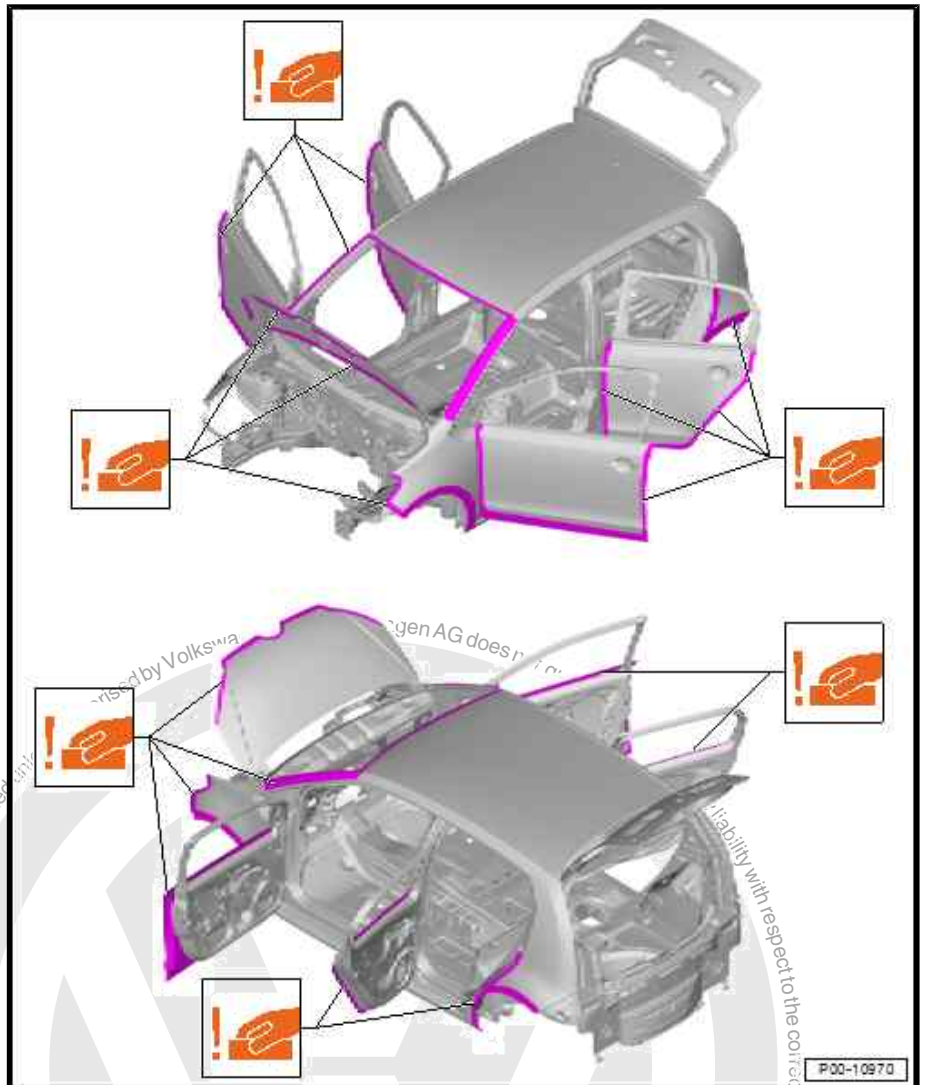

**i** Note

- ◆ The marked areas are exposed to stone chipping.
  - ◆ When sanding these areas, note thickness of the paint structure and avoid sanding through. This is the only way to ensure long-term corrosion protection.
  - ◆ Any areas that are sanded through must be treated according to ⇒ General paint information; Rep. gr. 00; General notes; Work instructions for underseal and anti-chip coating.
- It is recommended to carefully sand the marked area by hand to avoid “sanding through” the cathodic dip primer.

**Bonnet and rear lid**

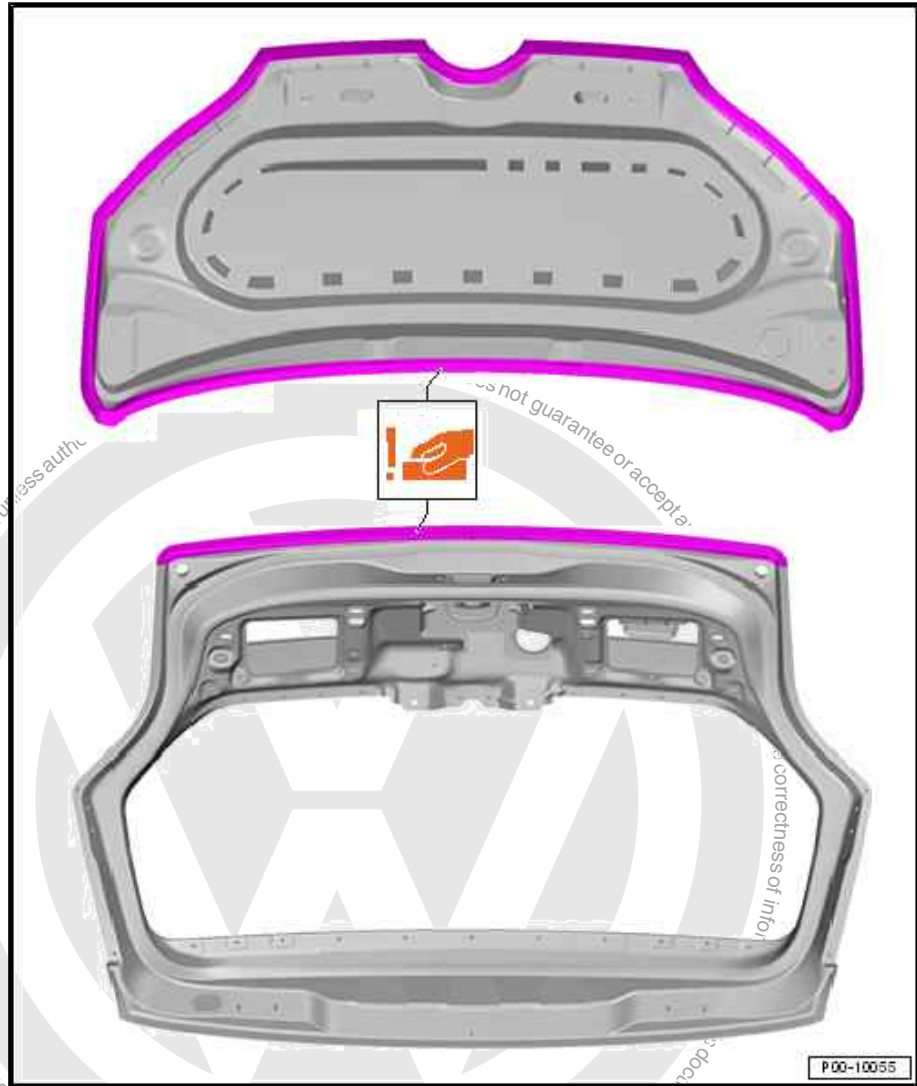

#### Note

- ◆ *The marked areas are exposed to stone chipping.*
  - ◆ *When sanding these areas, note thickness of the paint structure and avoid sanding through. This is the only way to ensure long-term corrosion protection.*
  - ◆ *Any areas that are sanded through must be treated according to ⇒ General paint information; Rep. gr. 00; General notes; Work instructions for underseal and anti-chip coating .*
- It is recommended to carefully sand the marked area by hand to avoid “sanding through” the cathodic dip primer.





## 4 Masked sectors

⇒ ["4.1 Masking areas, front body", page 29](#)

⇒ ["4.2 Masking areas, rear body", page 38](#)

### 4.1 Masking areas, front body

Masking areas, left plenum chamber

A - Threads and contact surfaces free of sealant and wax build-up

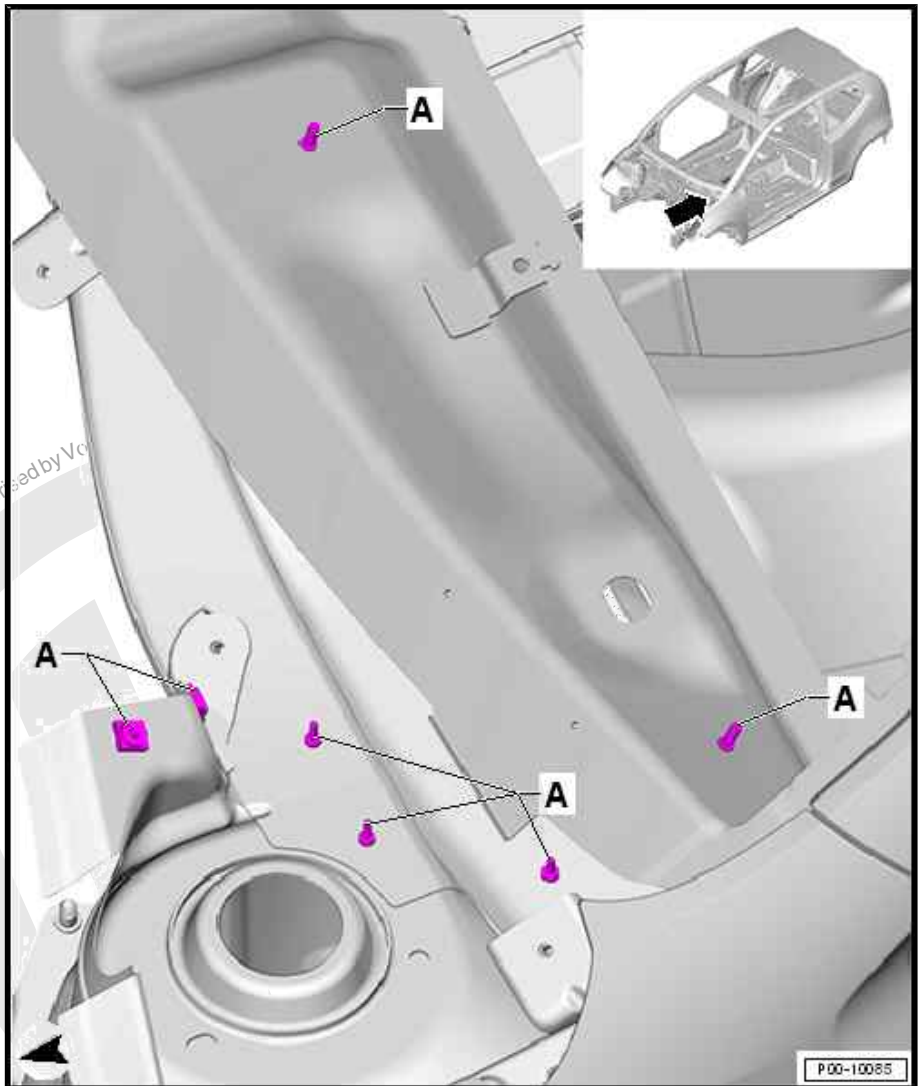

Masking areas, centre plenum chamber



**A - Threads and contact surfaces free of sealant and wax build-up**

ed by copyright. Copying for private or commercial purposes, in part or in whole, is not permitted unless authorised by Volks

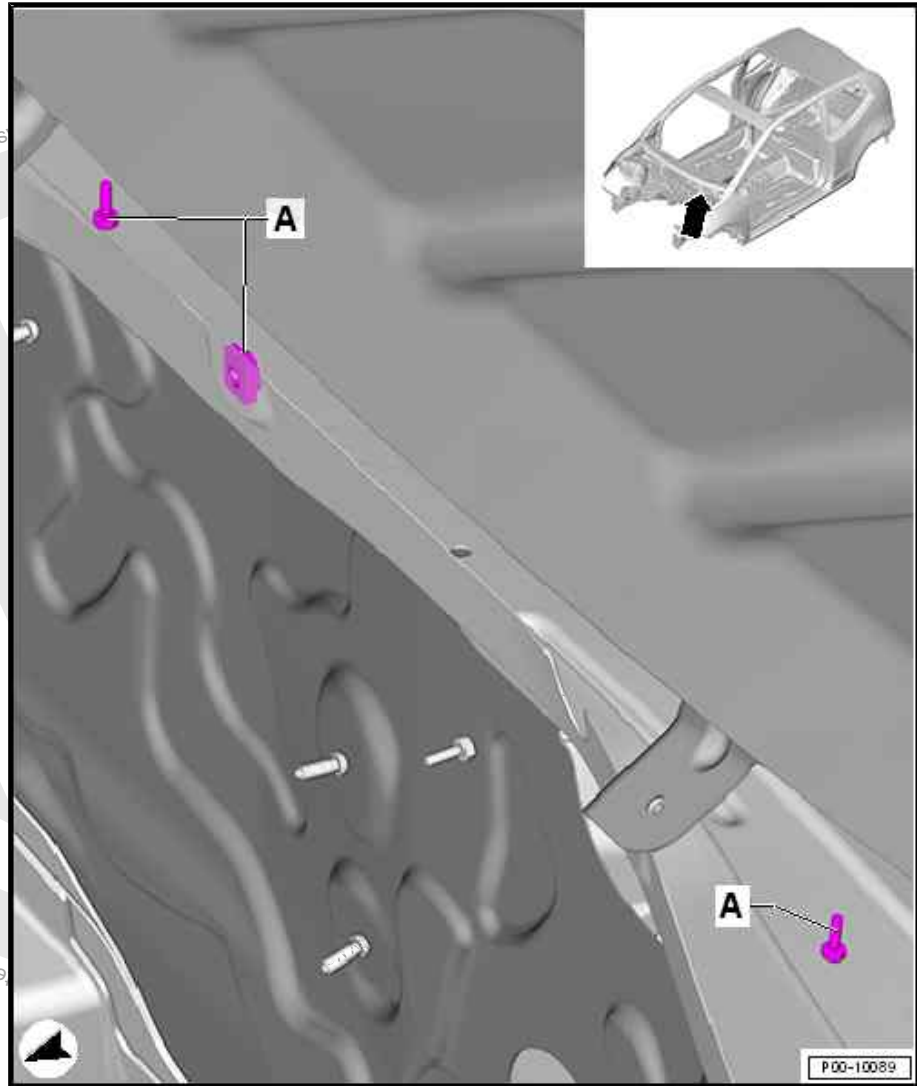

**Masking areas, right plenum chamber**



**A - Threads and contact surfaces free of sealant and wax build-up**

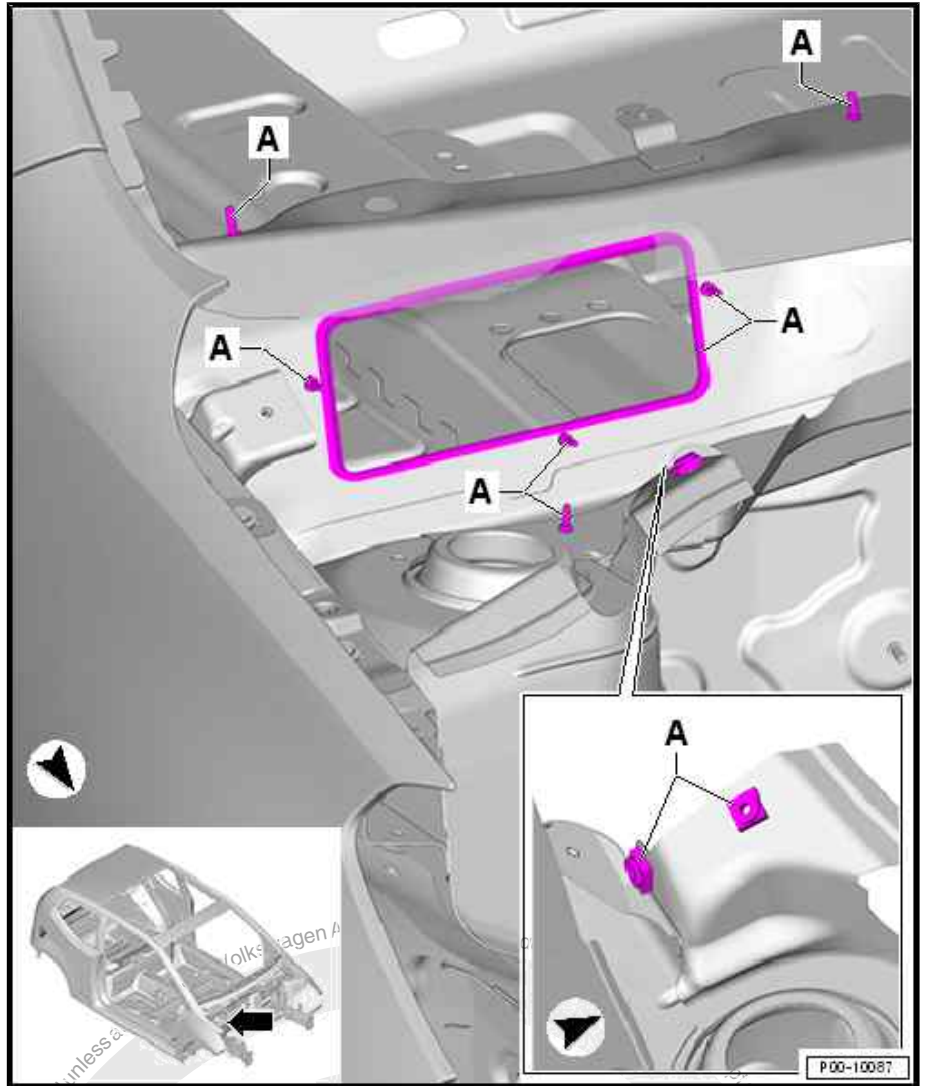

**Masking areas, right engine compartment**

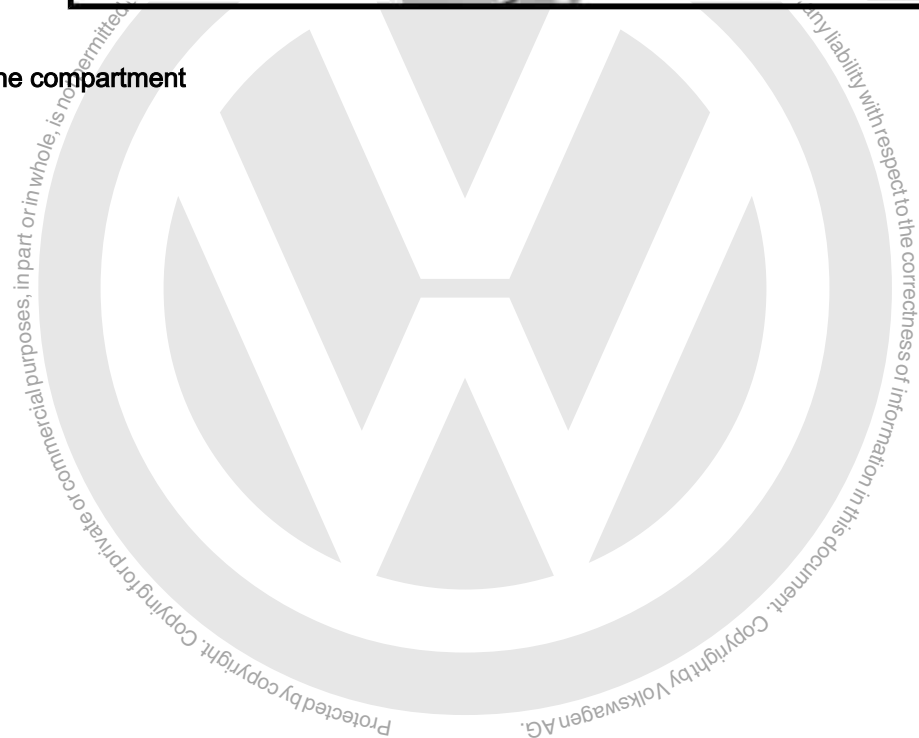



**A - Threads and contact surfaces free of sealant and wax build-up**

**B - No paint, sealant or wax on threads**

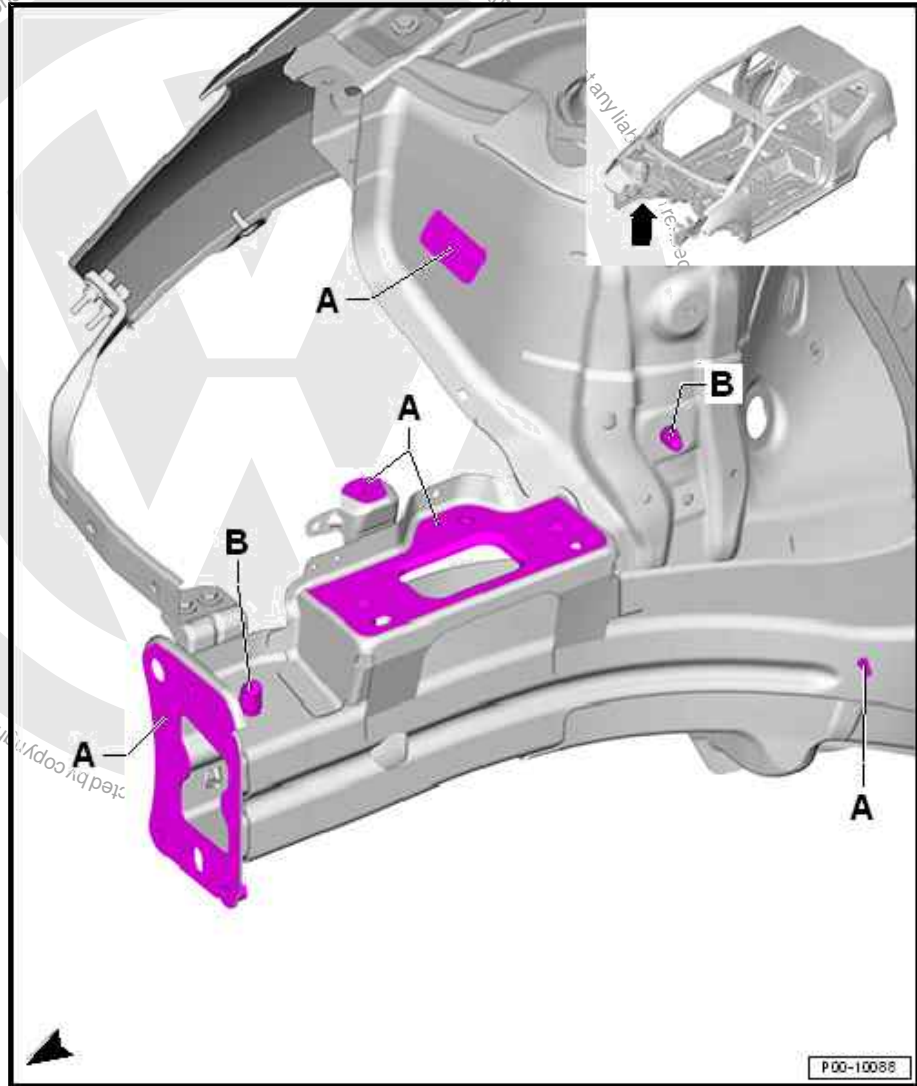

Masking areas, centre engine compartment



A - Threads and contact surfaces free of sealant and wax build-up

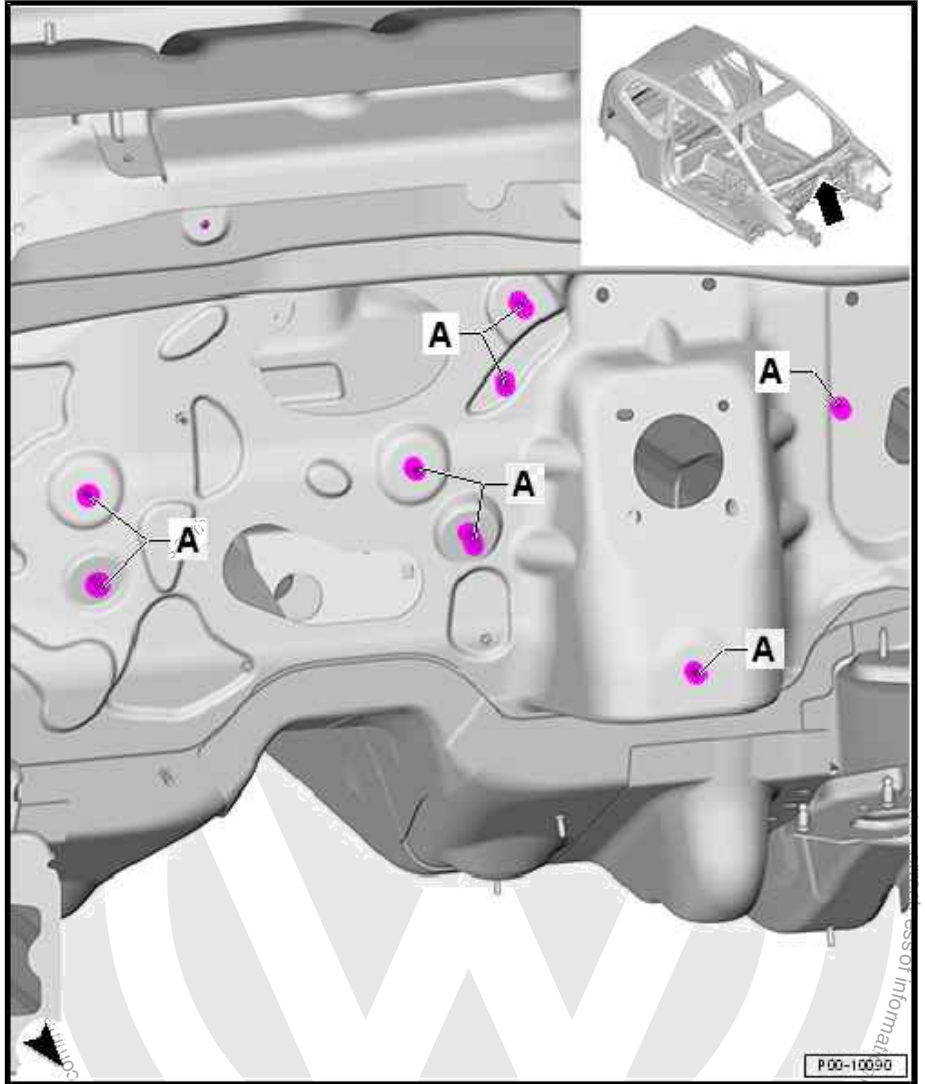

Masking areas, left engine compartment



**A - Threads and contact surfaces free of sealant and wax build-up**

**B - No paint, sealant or wax on threads**

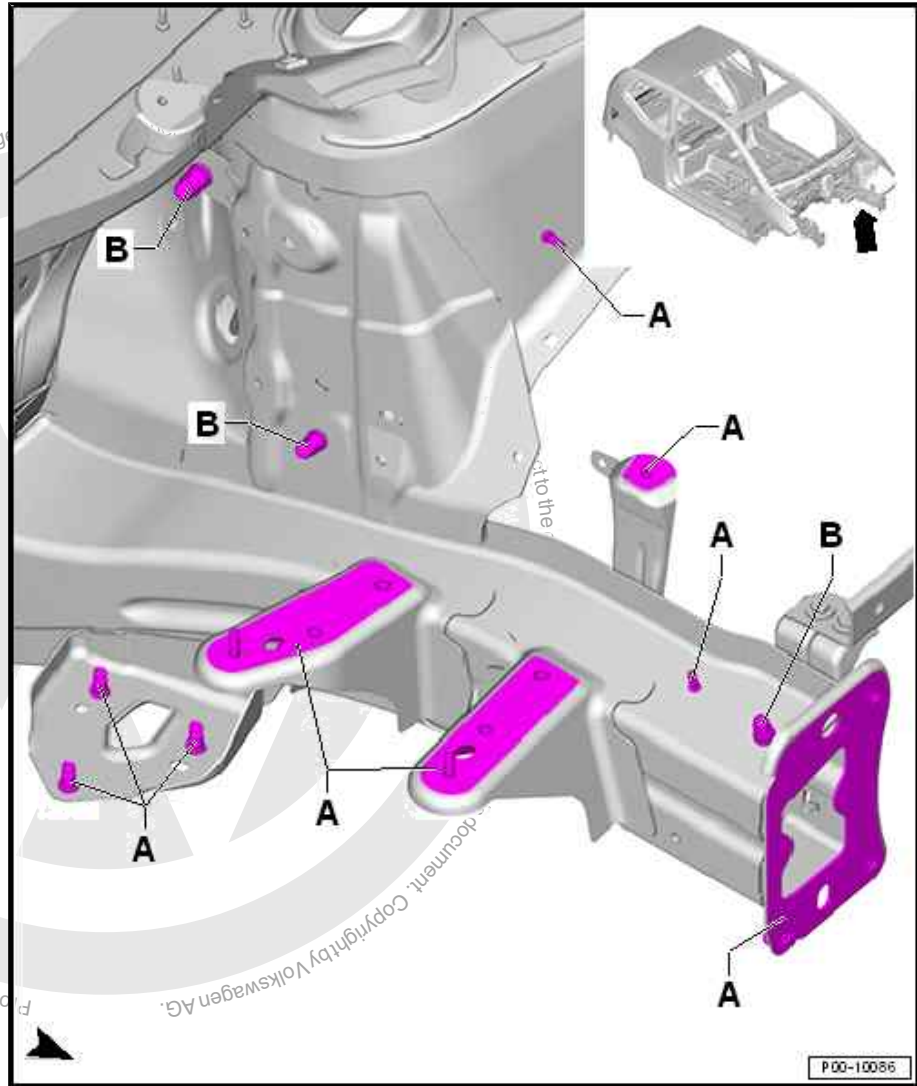

Masking areas, front left wheel housing



**B** - No paint, sealant or wax on threads

**C** - No sealant on thread or contact surface

**D** - No sealant on threads or contact surfaces on either side

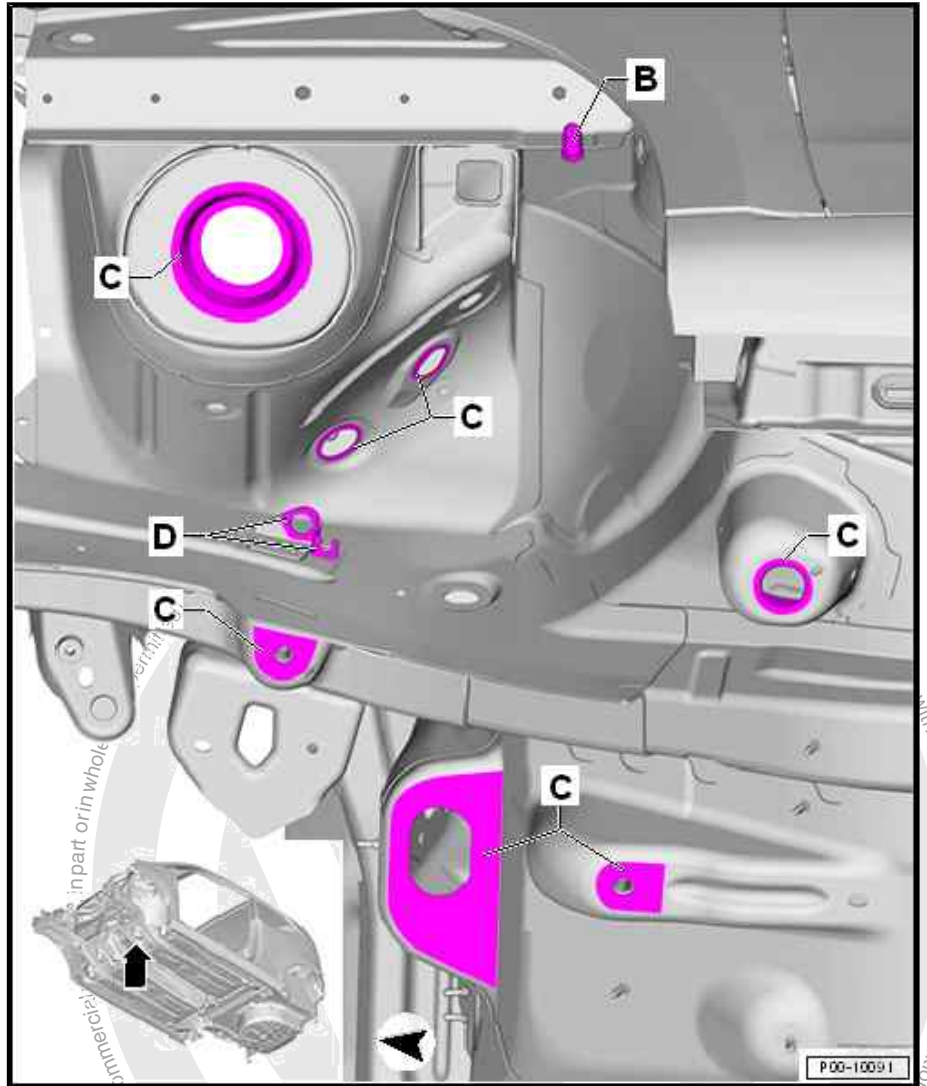

Masking areas, front right wheel housing



**C - No sealant on thread or contact surface**

**D - No sealant on threads or contact surfaces on either side**

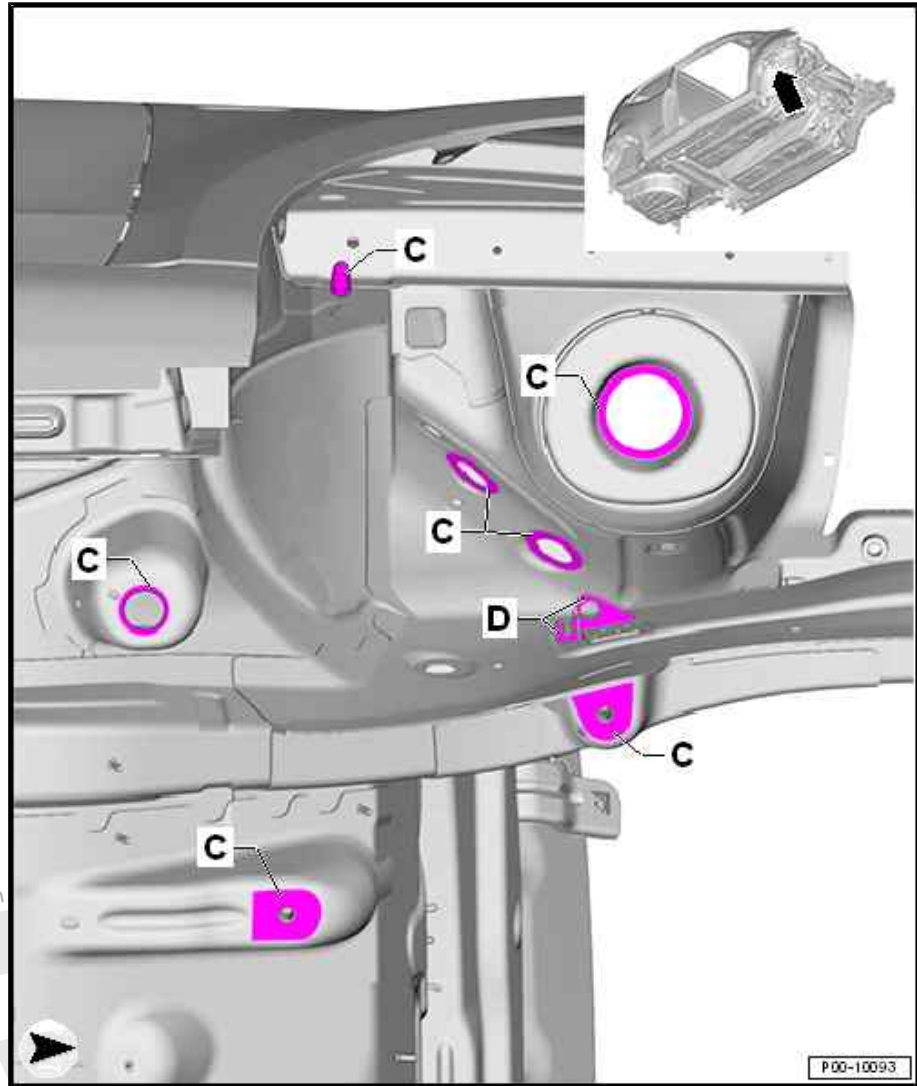

**Masking areas, inner side member**

Illustration shows left side. The right side is the mirror image.





**A - Threads and contact surfaces free of sealant and wax build-up**

**B - No paint, sealant or wax on threads**

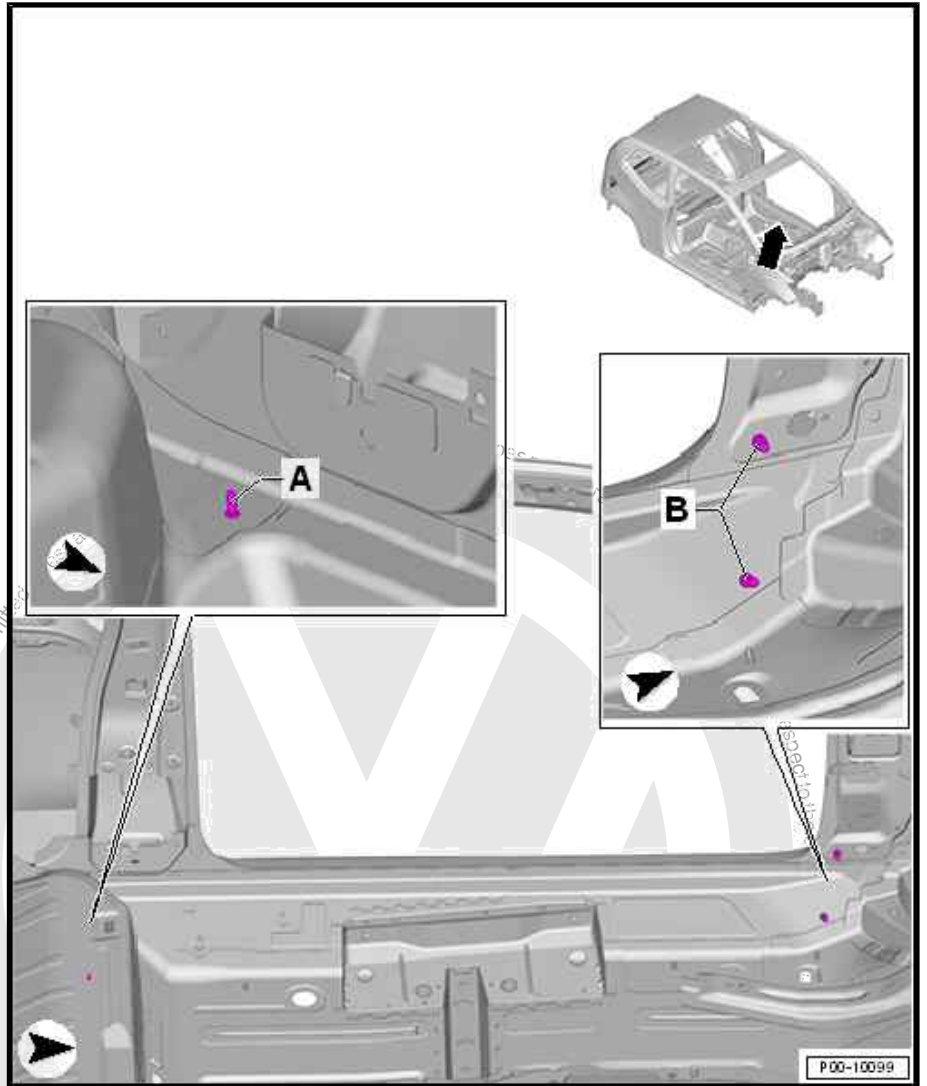



## 4.2 Masking areas, rear body

### Masking areas, underbody

A - Threads and contact surfaces free of sealant and wax build-up

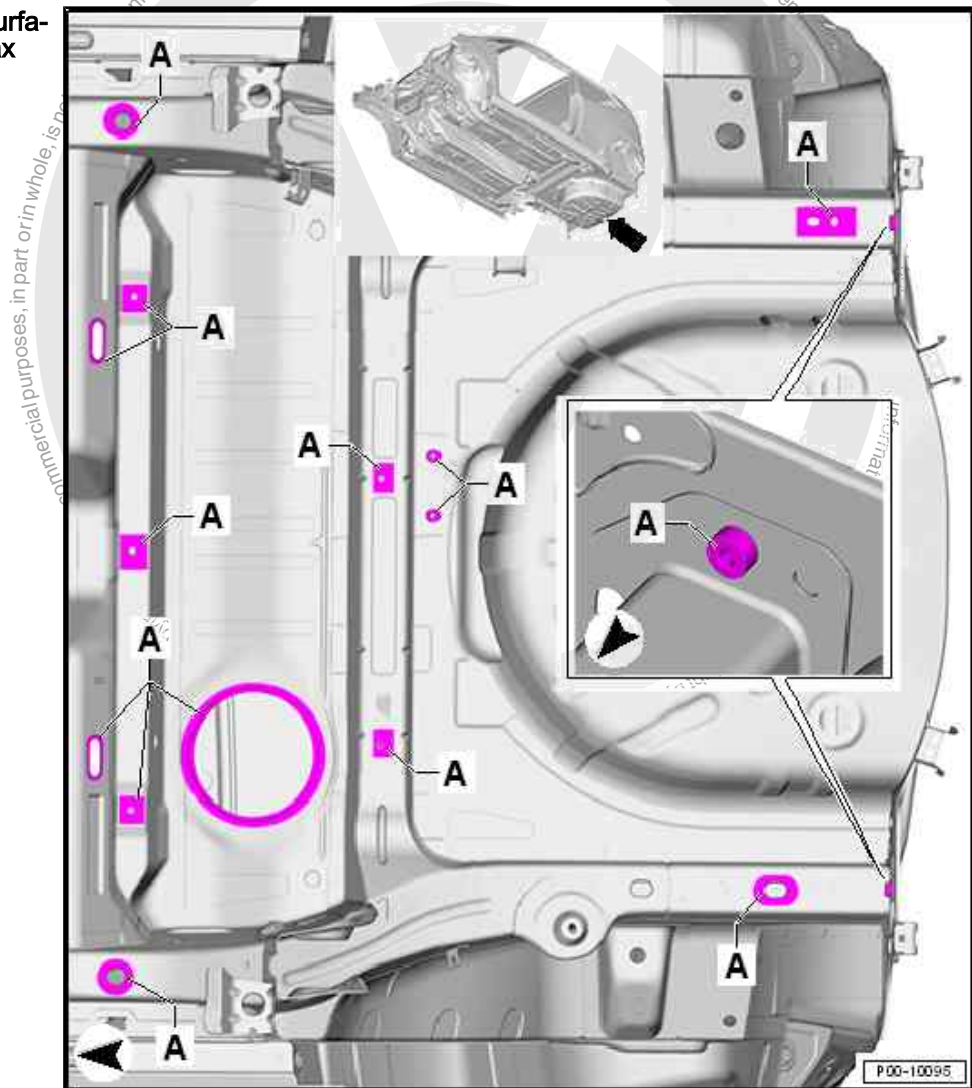

### Masking areas, underbody of CNG-fuel vehicle



**A - Threads and contact surfaces free of sealant and wax build-up**

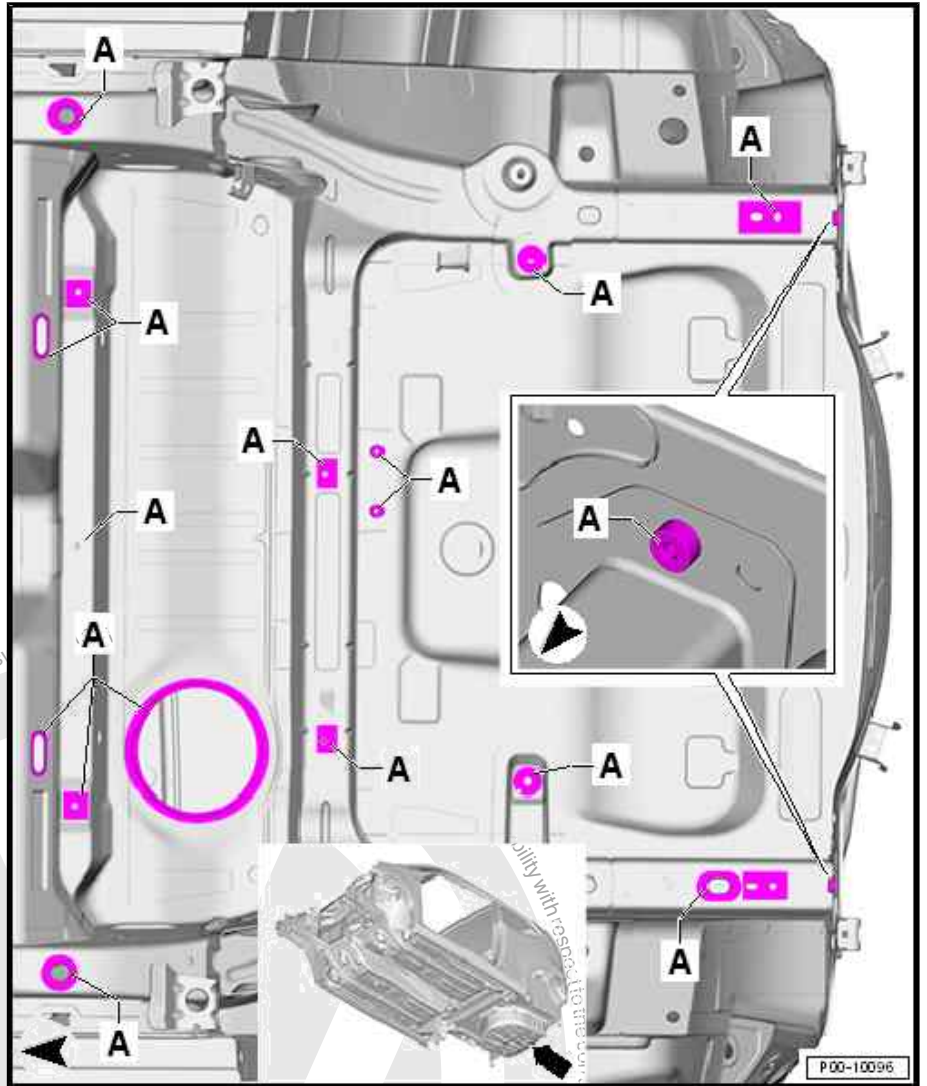

**Masking areas, rear left wheel housing, up to model year 2016**



**C** - No sealant on thread or contact surface  
**D** - No sealant on threads or contact surfaces on either side

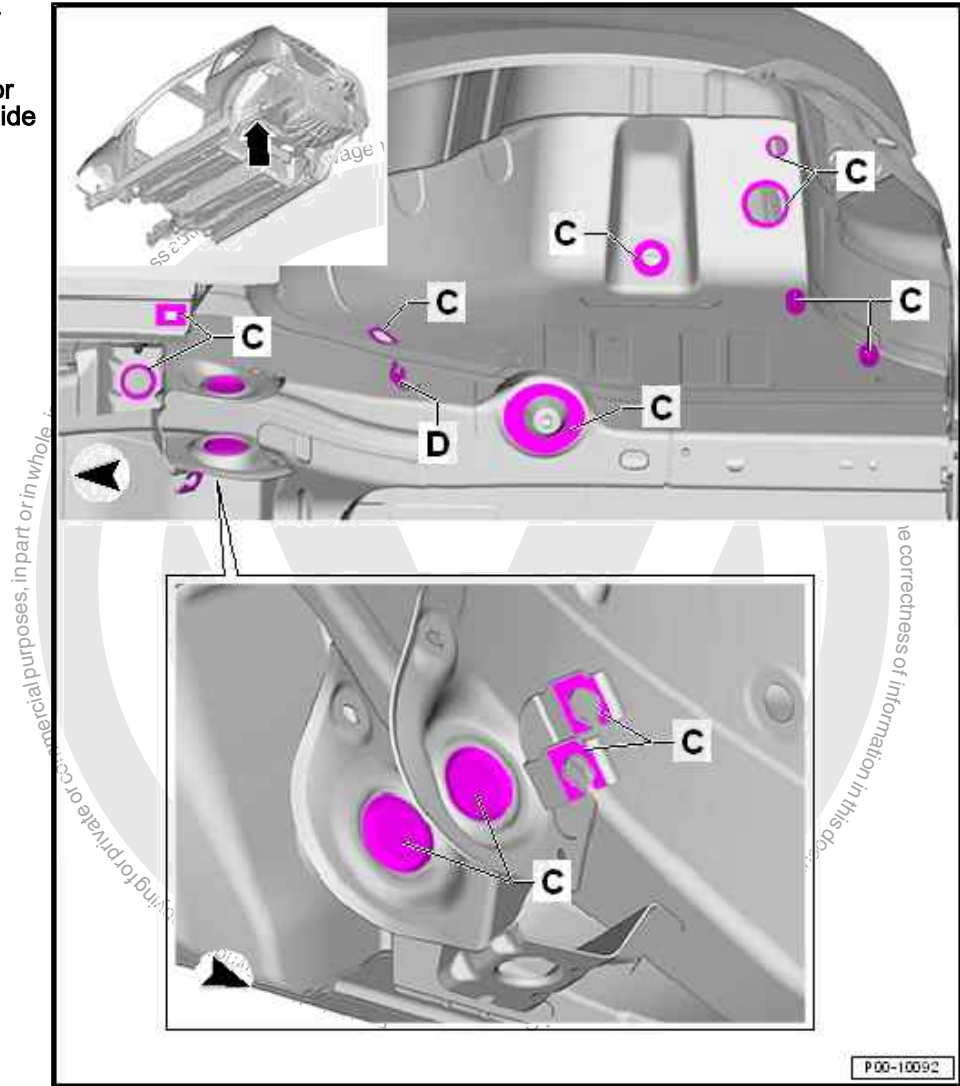

Masking areas, rear left wheel housing, as of model year 2017



**B** - Contact surface, threaded connections and axle mountings free of underseal

**C** - No sealant on thread or contact surface

**D** - No sealant on threads or contact surfaces on either side

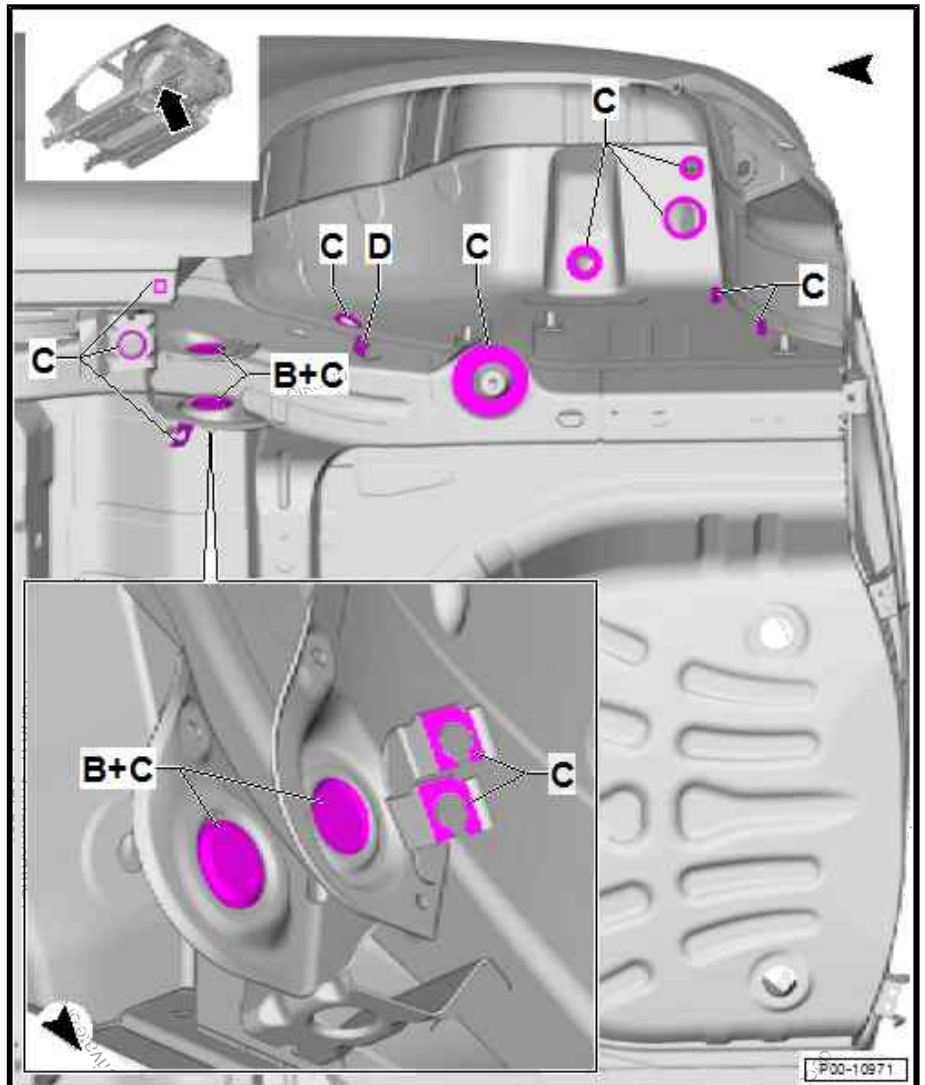

Masking areas, rear right wheel housing, up to model year 2016



**C - No sealant on thread or contact surface**

**D - No sealant on threads or contact surfaces on either side**

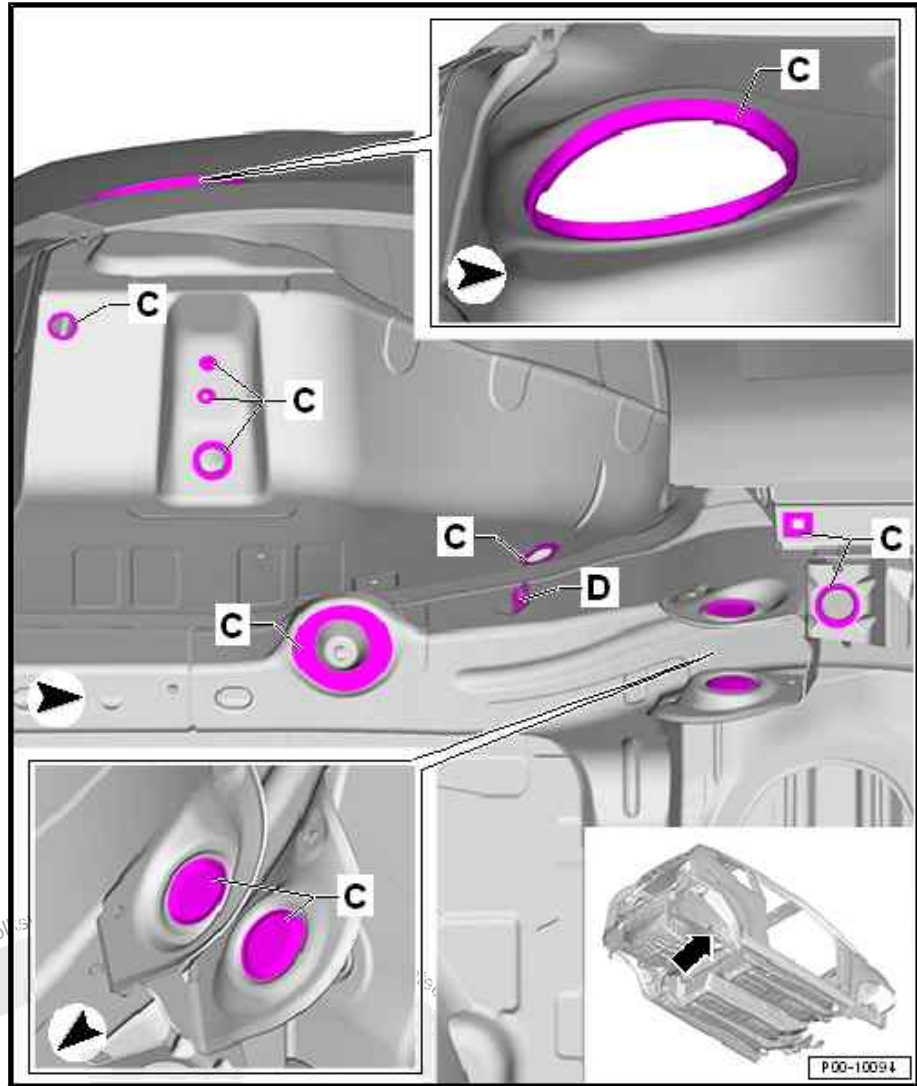

**Masking areas, rear right wheel housing, as of model year 2017**

Protected by copyright. Copying for private or commercial purposes, in part or in whole, is not permitted unless authorised by Volkswagen AG.

liability with respect to the correctness of information in this document. Copyright by Volkswagen AG.



**B** - Contact surface, threaded connections and axle mountings free of underseal

**C** - No sealant on thread or contact surface

**D** - No sealant on threads or contact surfaces on either side

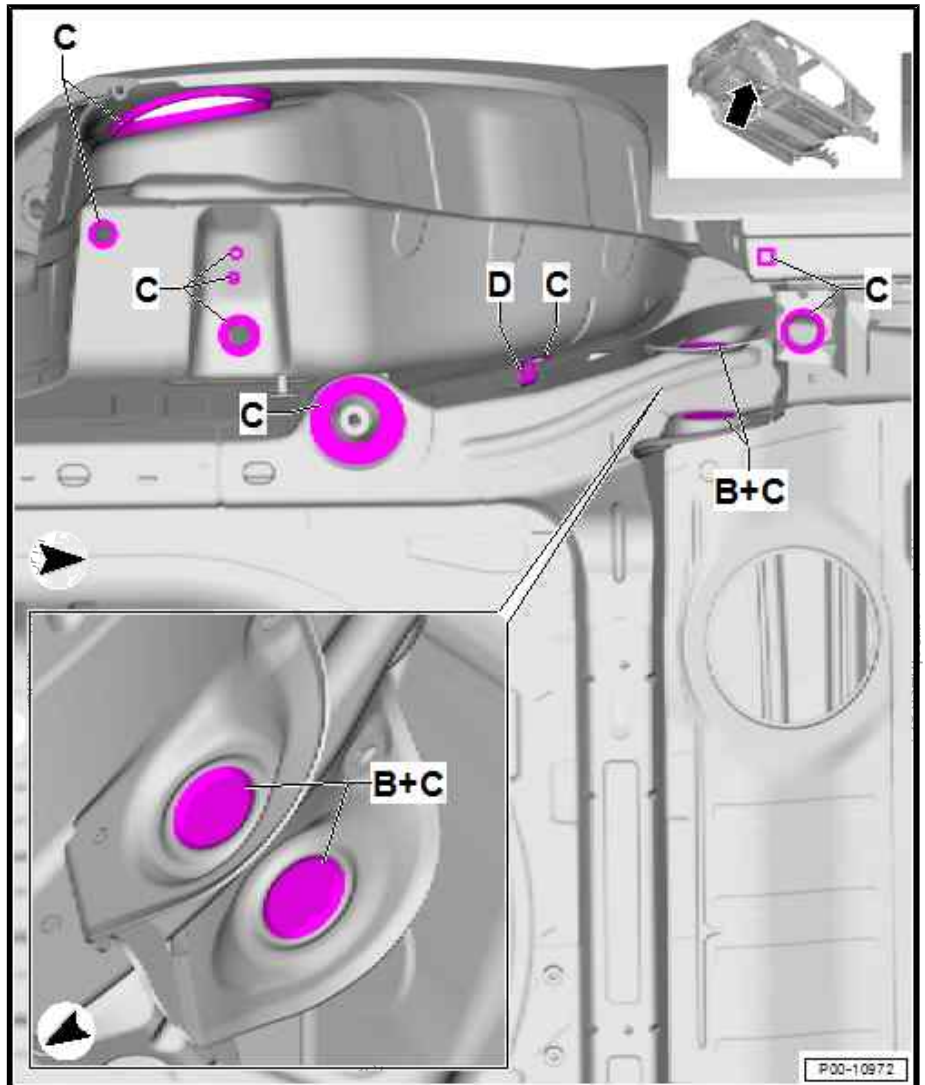

#### Masking areas, luggage compartment

Illustration shows left side. The right side is the mirror image.



**A - Threads and contact surfaces free of sealant and wax build-up**

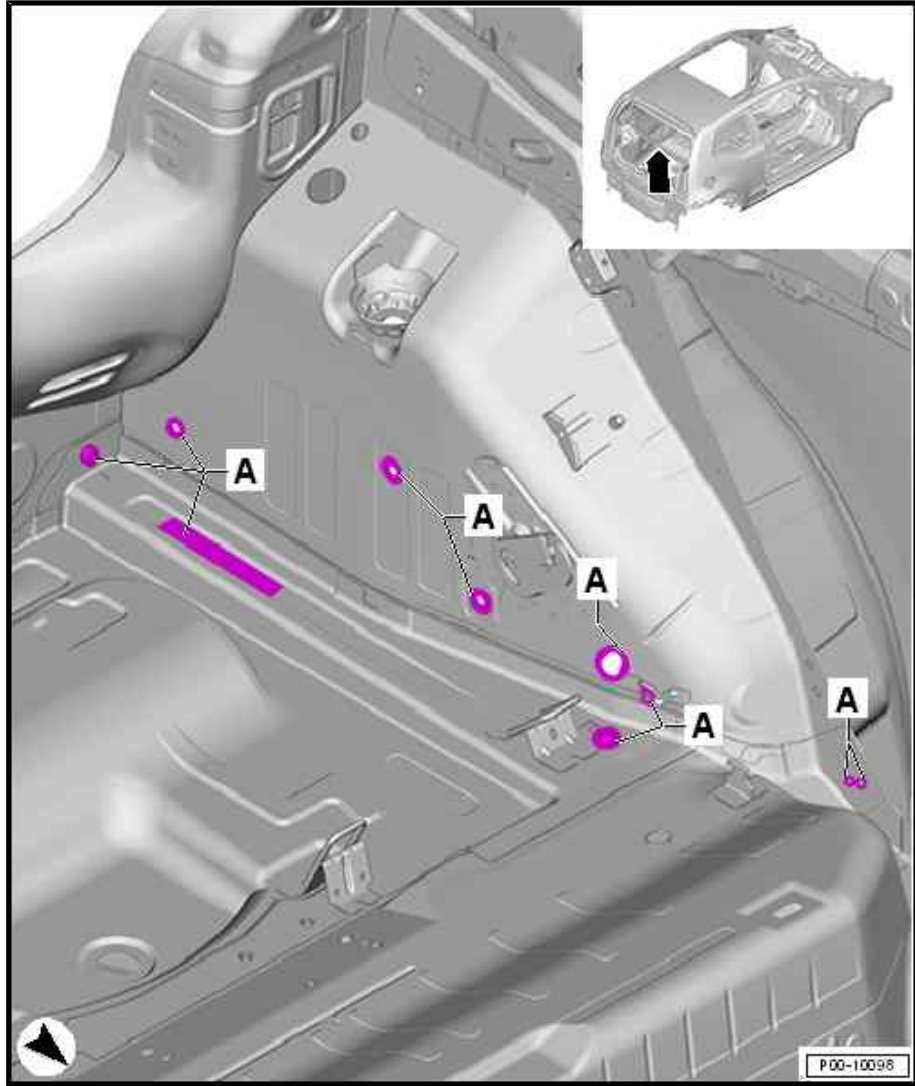

### Masking areas, rear body

Illustration shows left side. The right side is the mirror image.

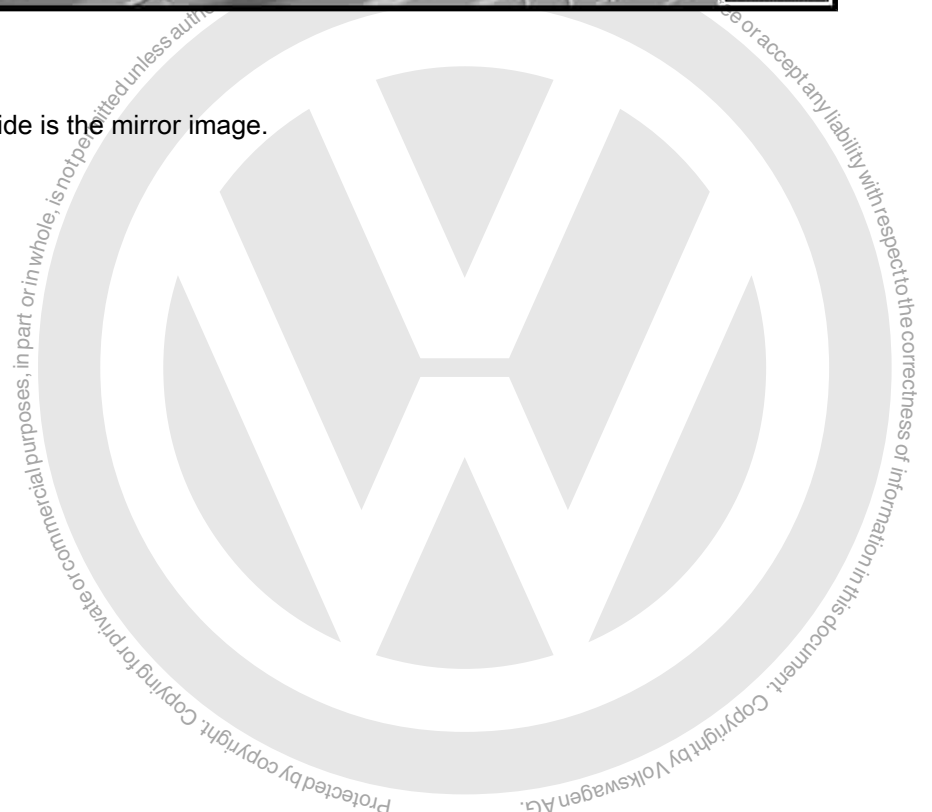





**A - Threads and contact surfaces free of sealant and wax build-up**

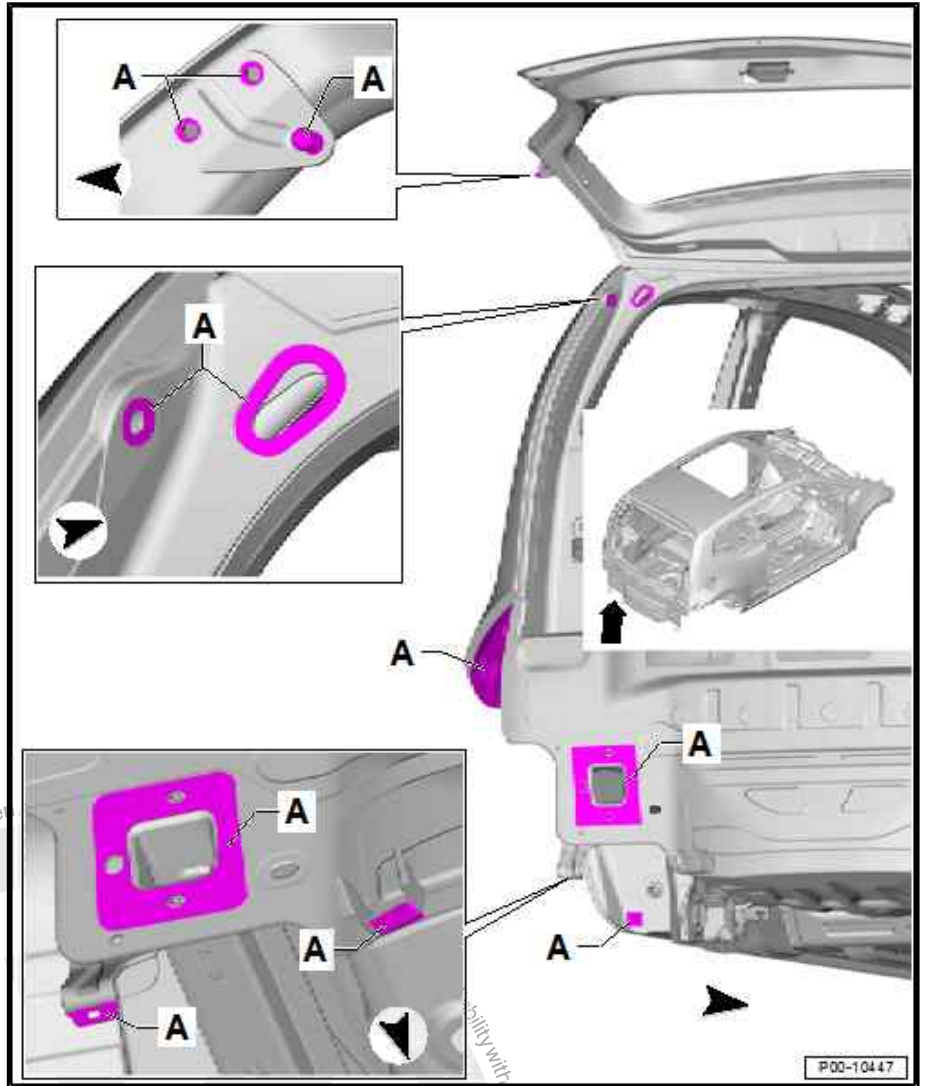

Protected by copyright. Copying for private or commercial purposes, in part or in whole, is not permitted unless authorised by Volkswagen AG.

ability with respect to the correctness of information in this document. Copyright by Volkswagen AG.



### 4.3 Masking areas Cross UP

#### Masking areas Cross UP

**E** - Surface free of wax and sealant

- Dimension -x-

□ 37 mm

- Dimension -y-

□ 45 mm

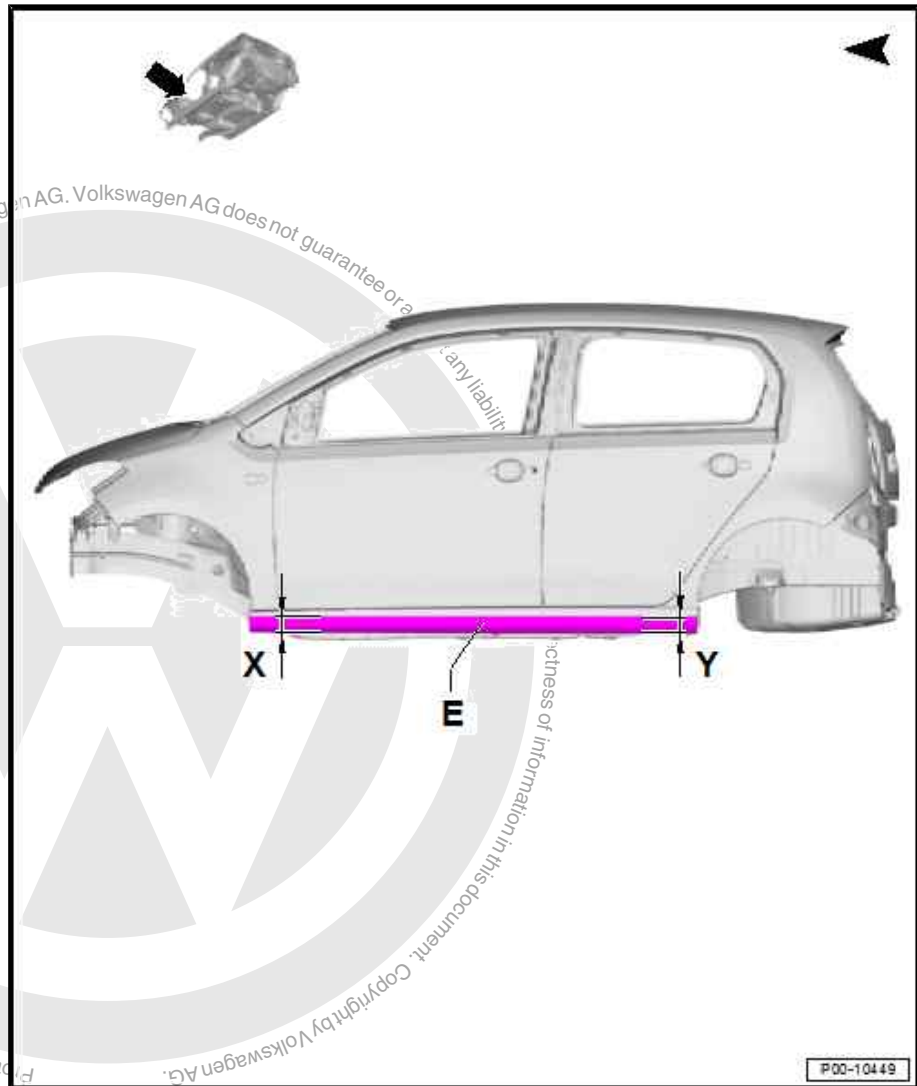



## 5 Seam sealing

⇒ ["5.1 Seam seals, front body", page 47](#)

⇒ ["5.2 Seam seals, centre body", page 55](#)

⇒ ["5.3 Seam seals, rear body", page 63](#)

### 5.1 Seam seals, front body



#### Note

- ◆ *When performing repair work, the seam sealing should be restored to match the original appearance and layer thickness.*
- ◆ *To avoid damage or faulty operation, brush seam seals smooth near parts which must be attached.*
- ◆ *Water drainage holes must remain clear.*
- ◆ *All threaded studs and welded nuts with metric threads as well as all other studs and contact surfaces for assembly must be functional following the extent of the sealing work.*
- ◆ *Sealant must never be applied to bare substrates. Substrates must always be surfaced first.*

#### Seam seals, left side of engine compartment, up to model year 2016

Illustration shows left side. The right side is the mirror image.



- **Fine seam sealing**

- ❑ Fine seam seals require that the sealant extend at least 3 mm from the seam in each direction and must have a thickness of 1.5 mm to 2 mm.

- **Coarse seam sealing**

- ❑ Coarse seam seals require that the sealant be applied at least 8 mm wide and 2 mm high.

- **Smoothing seals**

- ❑ Sealant in the marked areas must be smoothed following application.

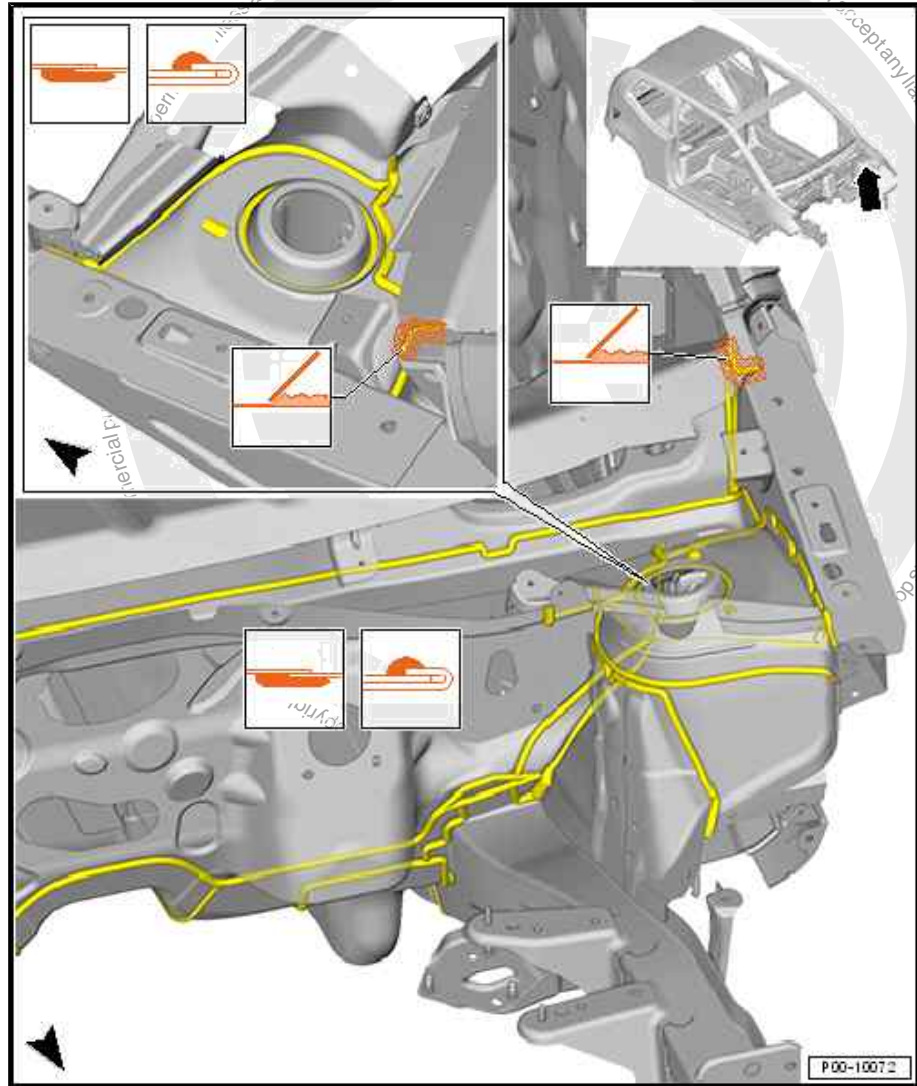

**Note**

*When smoothing the sealant seam, ensure that the sheet metal edges which are to be protected are not exposed. The metal must be covered with a sufficiently thick layer of PVC.*

**Seam seals, left side of engine compartment, as of model year 2017**

Illustration shows left side. The right side is the mirror image.



**- Fine seam sealing**

- ❑ Fine seam seals require that the sealant extend at least 3 mm from the seam in each direction and must have a thickness of 1.5 mm to 2 mm.

**- Coarse seam sealing**

- ❑ Coarse seam seals require that the sealant be applied at least 8 mm wide and 2 mm high.

**- Smoothing seals**

- ❑ Sealant in the marked areas must be smoothed following application.

**- Brushing seals**

- ❑ Sealant in the marked areas must be brushed following application.

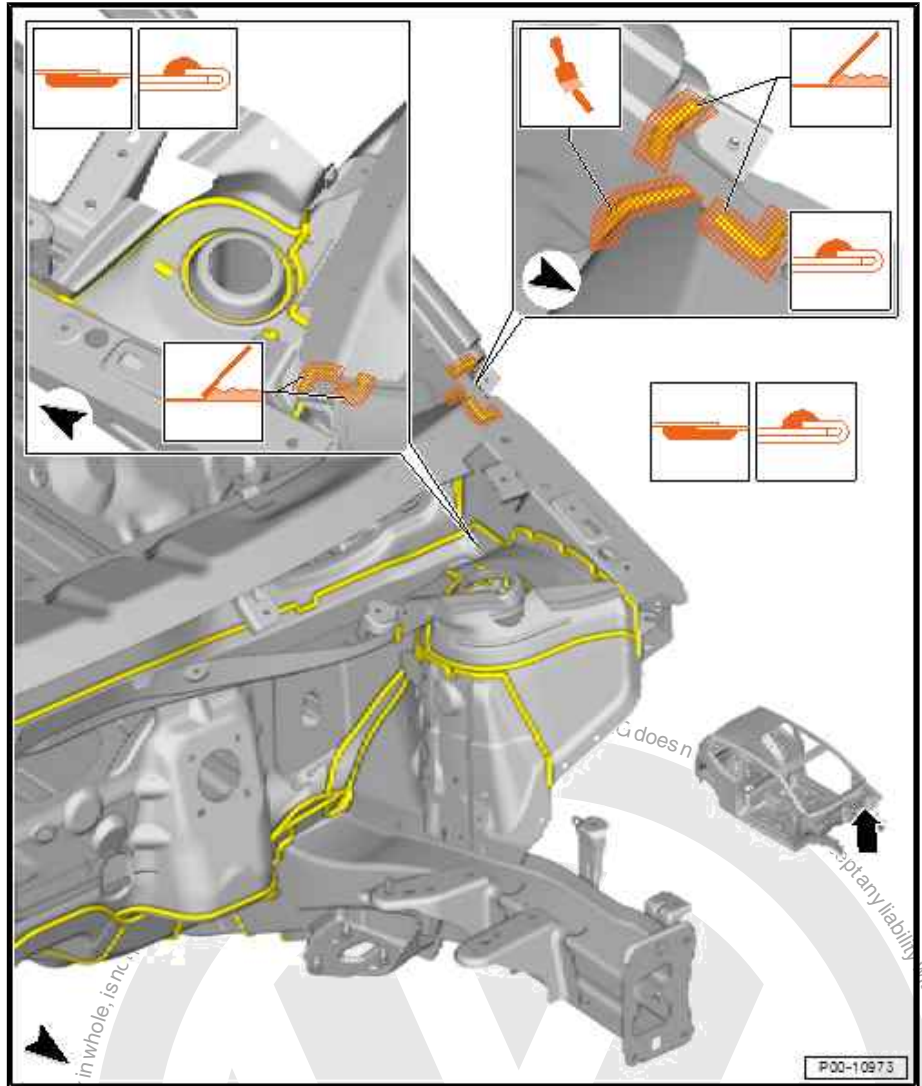

**i Note**

*When smoothing or brushing the sealant seam, ensure that the sheet metal edges which are to be protected are not exposed. The metal must be covered with a sufficiently thick layer of PVC.*

**Seam seals, left wheel housing, up to model year 2016**

Illustration shows left side. The right side is the mirror image.



**- Fine seam sealing**

- ❑ Fine seam seals require that the sealant extend at least 3 mm from the seam in each direction and must have a thickness of 1.5 mm to 2 mm.

**- Coarse seam sealing**

- ❑ Coarse seam seals require that the sealant be applied at least 8 mm wide and 2 mm high.

**- Brushing seals**

- ❑ Sealant in the marked areas must be brushed following application.

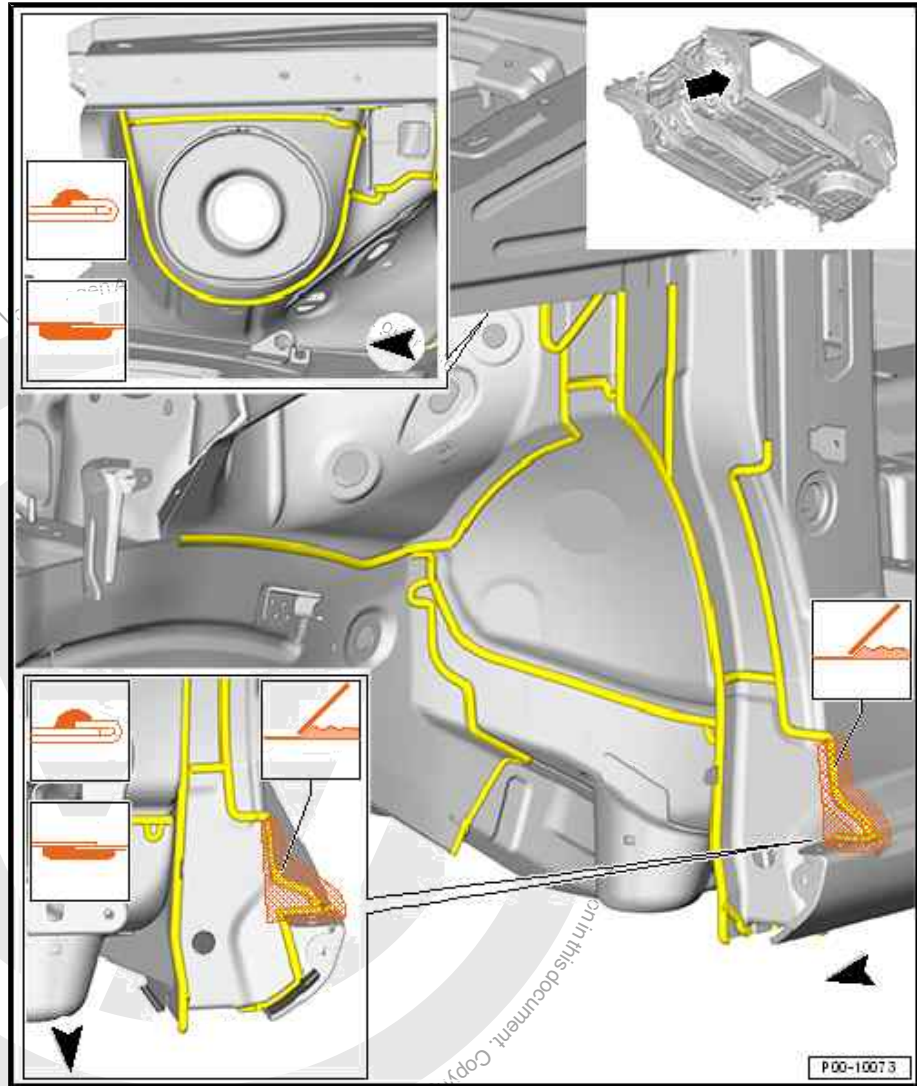

**Note**

*When smoothing the sealant seam, ensure that the sheet metal edges which are to be protected are not exposed. The metal must be covered with a sufficiently thick layer of PVC.*

**Seam seals, left wheel housing, as of model year 2017**



**- Fine seam sealing**

- ❑ Fine seam seals require that the sealant extend at least 3 mm from the seam in each direction and must have a thickness of 1.5 mm to 2 mm.

**- Coarse seam sealing**

- ❑ Coarse seam seals require that the sealant be applied at least 8 mm wide and 2 mm high.

**- Brushing seals**

- ❑ Sealant in the marked areas must be brushed following application.

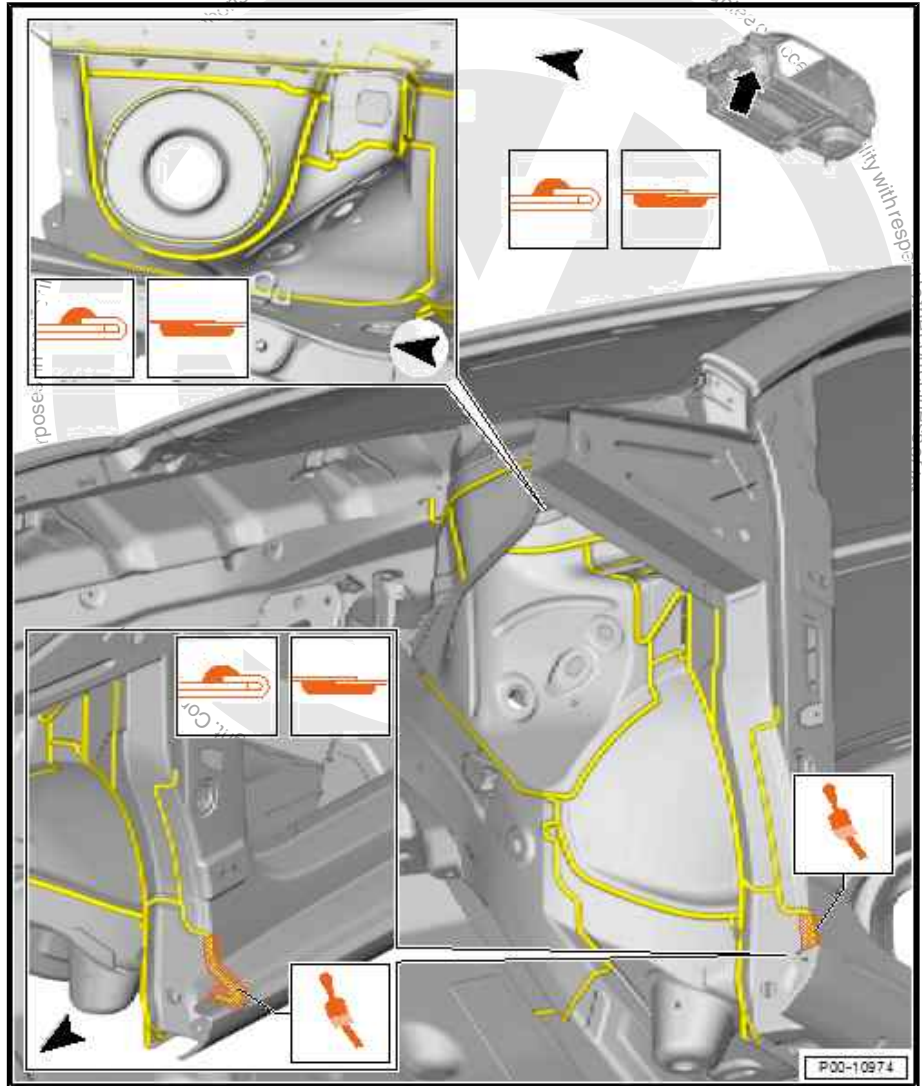

**i Note**

*When brushing the sealant seam, ensure that the sheet metal edges which are to be protected are not exposed. The metal must be covered with a sufficiently thick layer of PVC.*

**Seam seals, right wheel housing, as of model year 2017**



**- Fine seam sealing**

- ❑ Fine seam seals require that the sealant extend at least 3 mm from the seam in each direction and must have a thickness of 1.5 mm to 2 mm.

**- Coarse seam sealing**

- ❑ Coarse seam seals require that the sealant be applied at least 8 mm wide and 2 mm high.

**- Brushing seals**

- ❑ Sealant in the marked areas must be brushed following application.

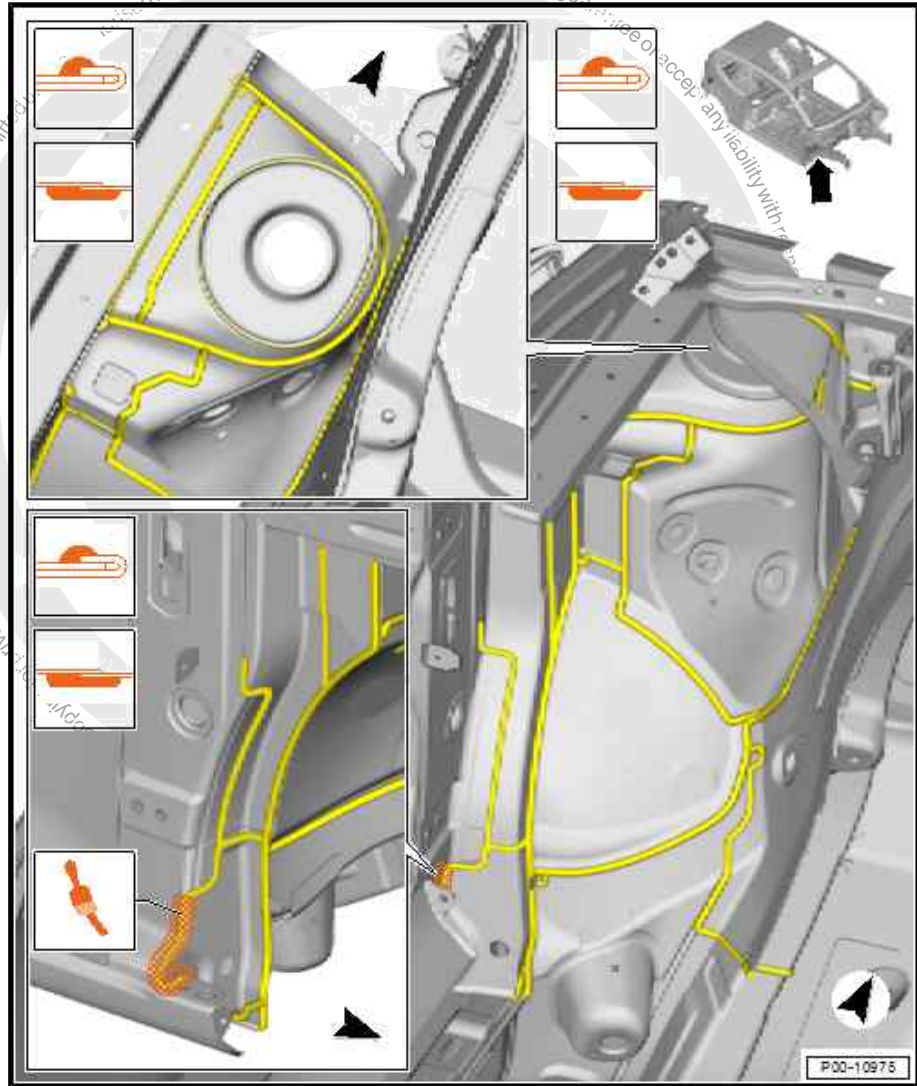

**Note**

*When brushing the sealant seam, ensure that the sheet metal edges which are to be protected are not exposed. The metal must be covered with a sufficiently thick layer of PVC.*

**Seam seals, inner side member, A-pillar reinforcement**





**- Fine seam sealing**

- ❑ Fine seam seals require that the sealant extend at least 3 mm from the seam in each direction and must have a thickness of 1.5 mm to 2 mm.

**- Smoothing seals**

- ❑ Sealant in the marked areas must be smoothed following application.

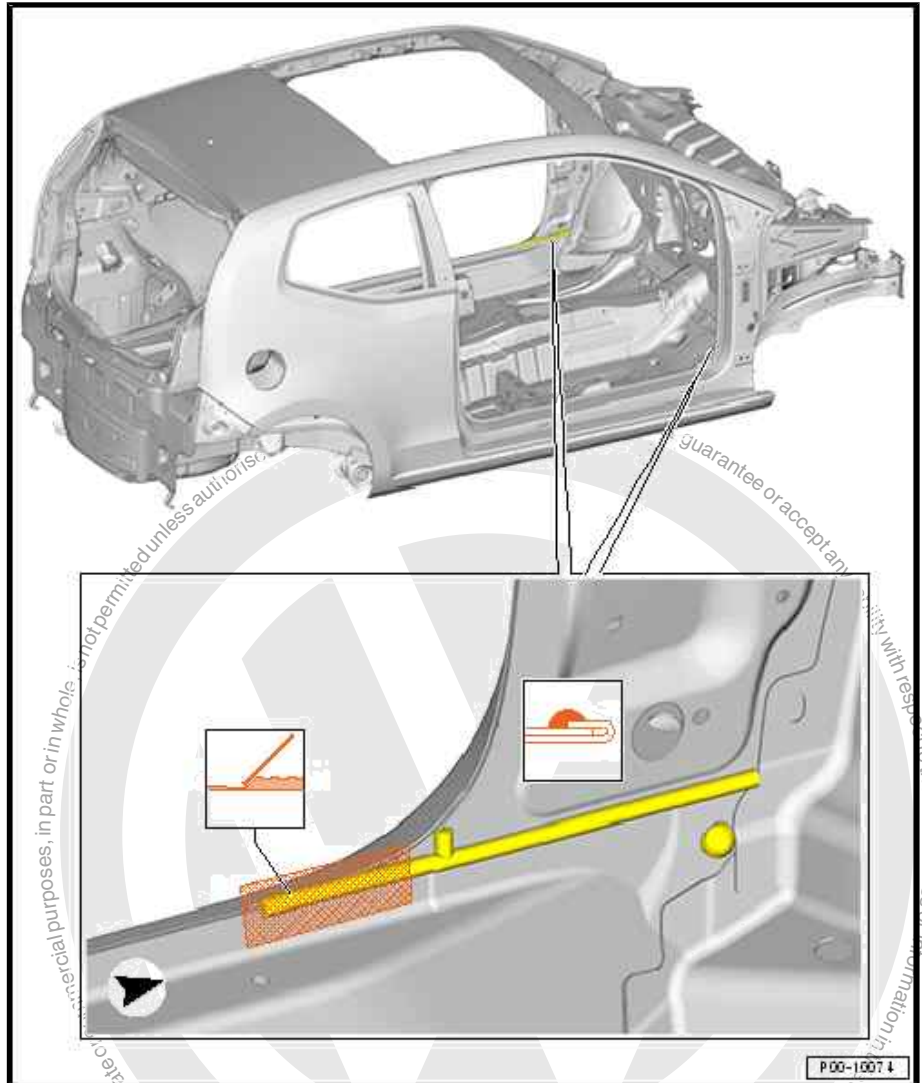

**i Note**

*When smoothing the sealant seam, ensure that the sheet metal edges which are to be protected are not exposed. The metal must be covered with a sufficiently thick layer of PVC.*

**Seam seals, bonnet**

Illustration shows left side. The right side is the mirror image.



**- Fine seam sealing**

- Fine seam seals require that the sealant extend at least 3 mm from the seam in each direction and must have a thickness of 1.5 mm to 2 mm.

**- Smoothing seals**

- Sealant in the marked areas must be smoothed following application.

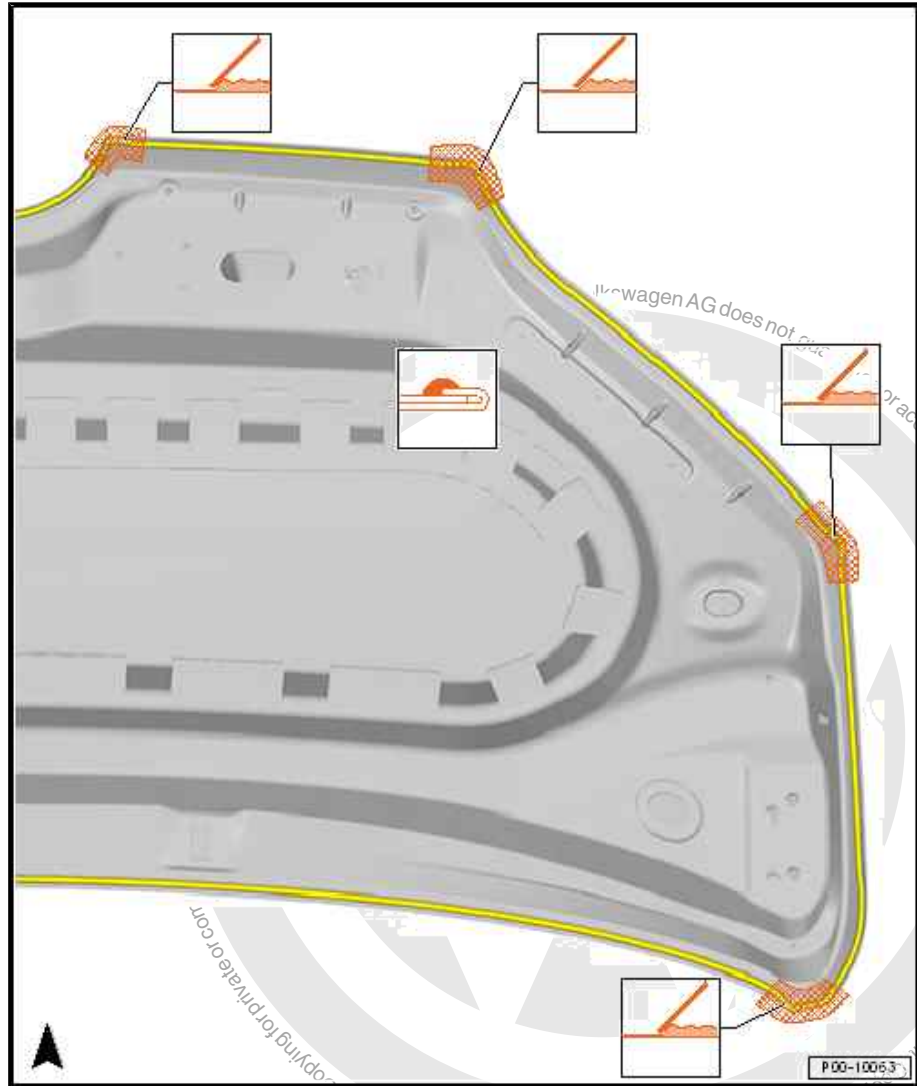

**Note**

*When smoothing the sealant seam, ensure that the sheet metal edges which are to be protected are not exposed. The metal must be covered with a sufficiently thick layer of PVC.*



## 5.2 Seam seals, centre body



### Note

- ◆ *When performing repair work, the seam sealing should be restored to match the original appearance and layer thickness.*
- ◆ *To avoid damage or faulty operation, brush seam seals smooth near parts which must be attached.*
- ◆ *Water drainage holes must remain clear.*
- ◆ *All threaded studs and welded nuts with metric threads as well as all other studs and contact surfaces for assembly must be functional following the extent of the sealing work.*
- ◆ *Sealant must never be applied to bare substrates. Substrates must always be surfaced first.*

### Seam seals on roof, up to model year 2016

#### - Fine seam sealing

- Fine seam seals require that the sealant extend at least 3 mm from the seam in each direction and must have a thickness of 1.5 mm to 2 mm.

#### - Smoothing seals

- Sealant in the marked areas must be smoothed following application.

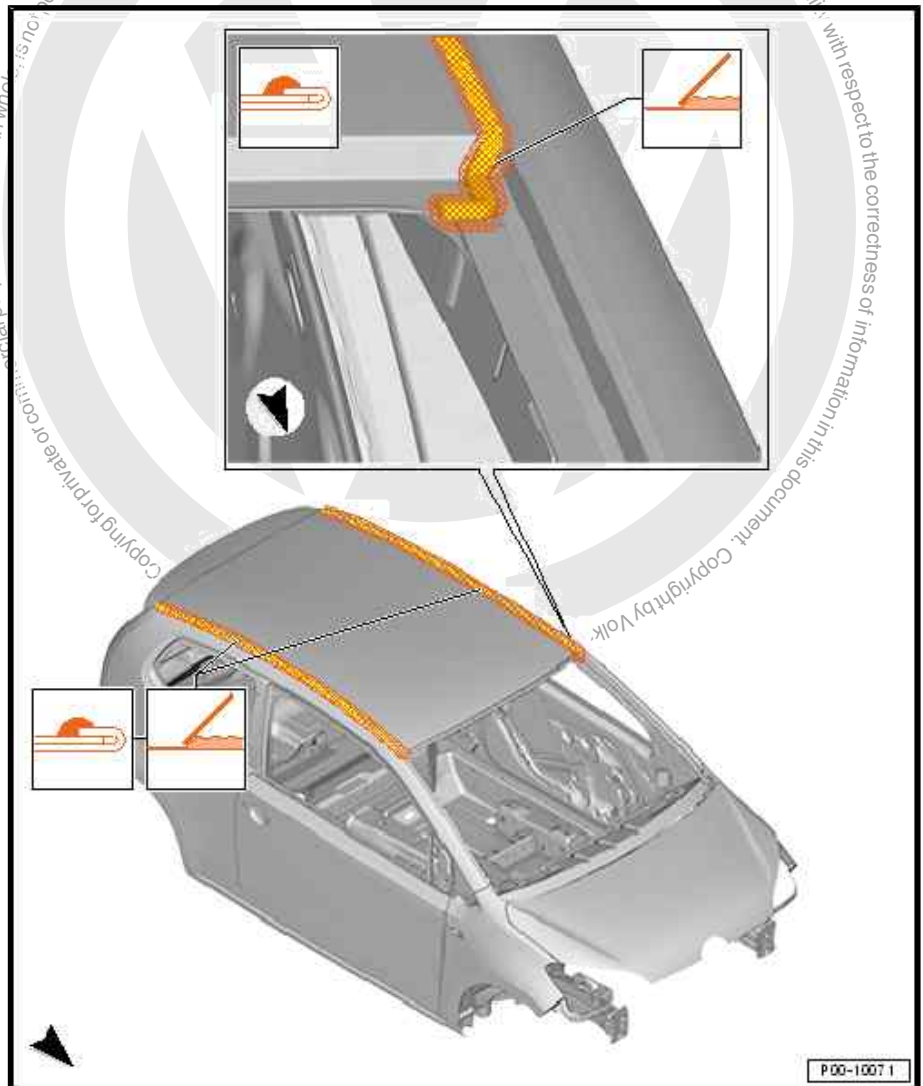

P 00-1007 1



### Note

*When smoothing the sealant seam, ensure that the sheet metal edges which are to be protected are not exposed. The metal must be covered with a sufficiently thick layer of PVC.*

### Seam seals on roof, as of model year 2017

#### - Fine seam sealing

- ❑ Fine seam seals require that the sealant extend at least 3 mm from the seam in each direction and must have a thickness of 1.5 mm to 2 mm.

#### - Smoothing seals

- ❑ Sealant in the marked areas must be smoothed following application.

#### - Brushing seals

- ❑ Sealant in the marked areas must be brushed following application.

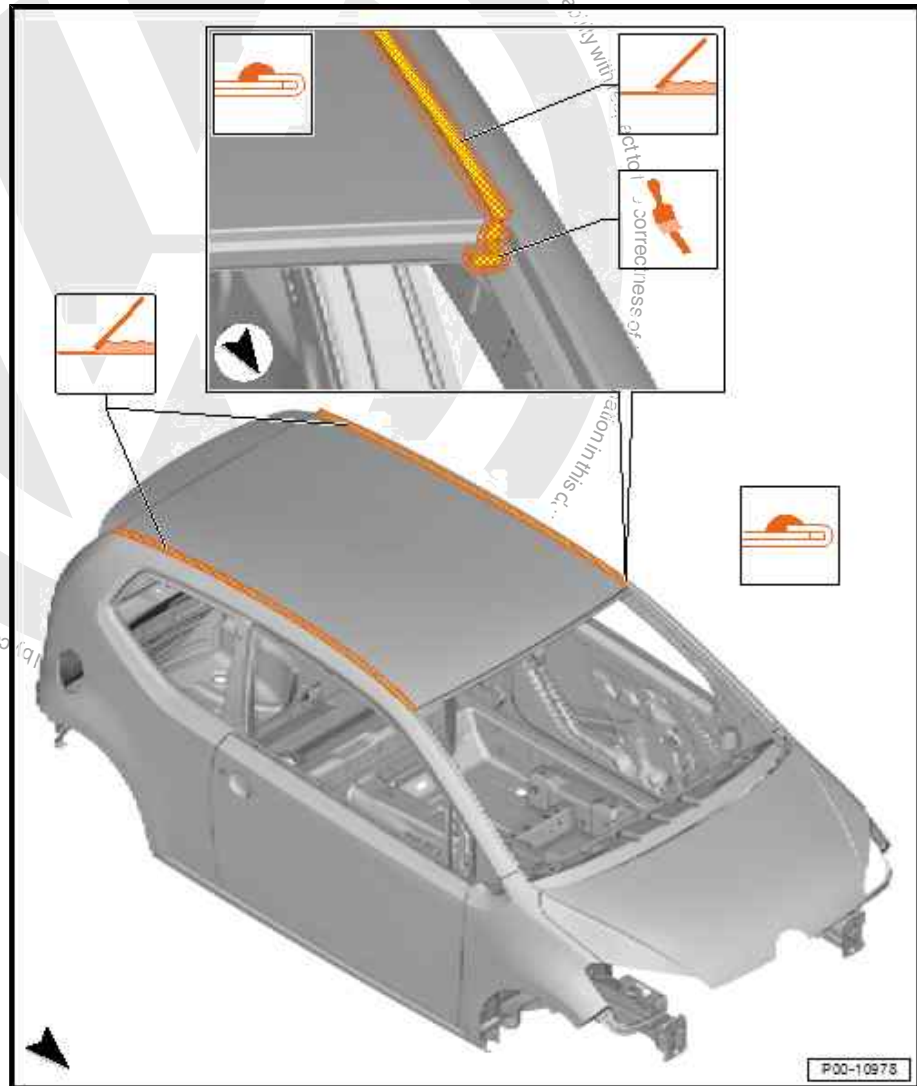

### Note

*When smoothing or brushing the sealant seam, ensure that the sheet metal edges which are to be protected are not exposed. The metal must be covered with a sufficiently thick layer of PVC.*

### Seam seals on roof (panoramic sliding sunroof), up to model year 2016



**- Fine seam sealing**

- ❑ Fine seam seals require that the sealant extend at least 3 mm from the seam in each direction and must have a thickness of 1.5 mm to 2 mm.

**- Smoothing seals**

- ❑ Sealant in the marked areas must be smoothed following application.

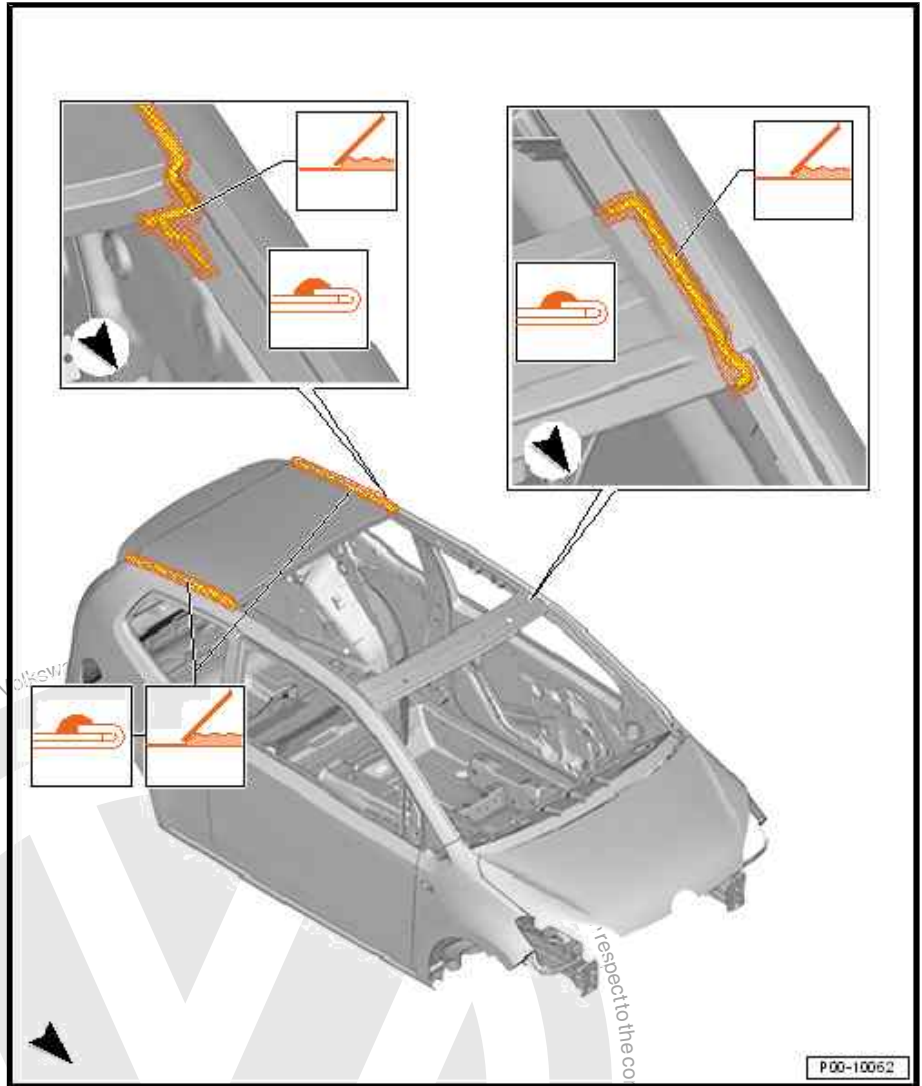

**Note**

*When smoothing the sealant seam, ensure that the sheet metal edges which are to be protected are not exposed. The metal must be covered with a sufficiently thick layer of PVC.*

**Seam seals on roof (panoramic sliding sunroof), as of model year 2017**



#### - Fine seam sealing

- ❑ Fine seam seals require that the sealant extend at least 3 mm from the seam in each direction and must have a thickness of 1.5 mm to 2 mm.

#### - Smoothing seals

- ❑ Sealant in the marked areas must be smoothed following application.

#### - Brushing seals

- ❑ Sealant in the marked areas must be brushed following application.

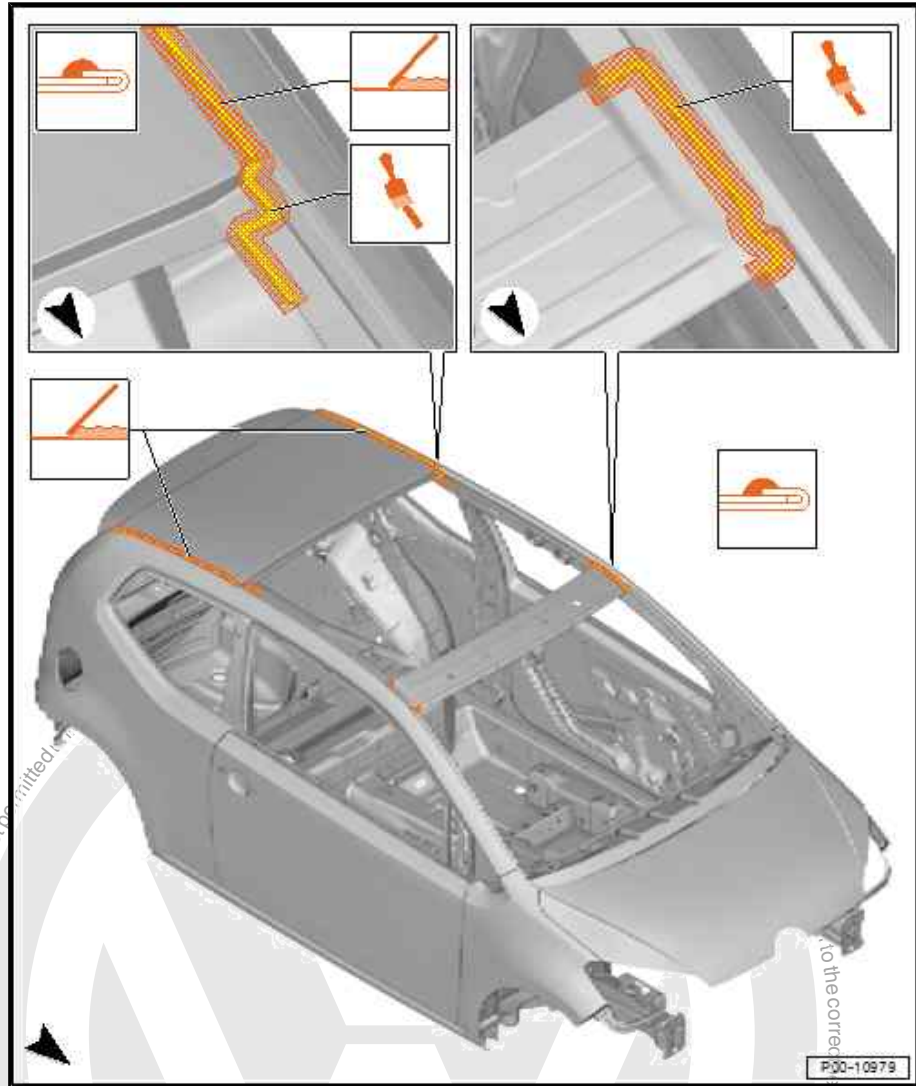

#### Note

*When smoothing or brushing the sealant seam, ensure that the sheet metal edges which are to be protected are not exposed. The metal must be covered with a sufficiently thick layer of PVC.*

#### Seam seals on doors, 2-door models

Illustration shows left side. The right side is the mirror image.



**- Fine seam sealing**

- ❑ Fine seam seals require that the sealant extend at least 3 mm from the seam in each direction and must have a thickness of 1.5 mm to 2 mm.

**- Smoothing seals**

- ❑ Sealant in the marked areas must be smoothed following application.

**- Sealing the folded seam groove**

- ❑ The marked areas must be closed following application of sealant to the folded seam groove.

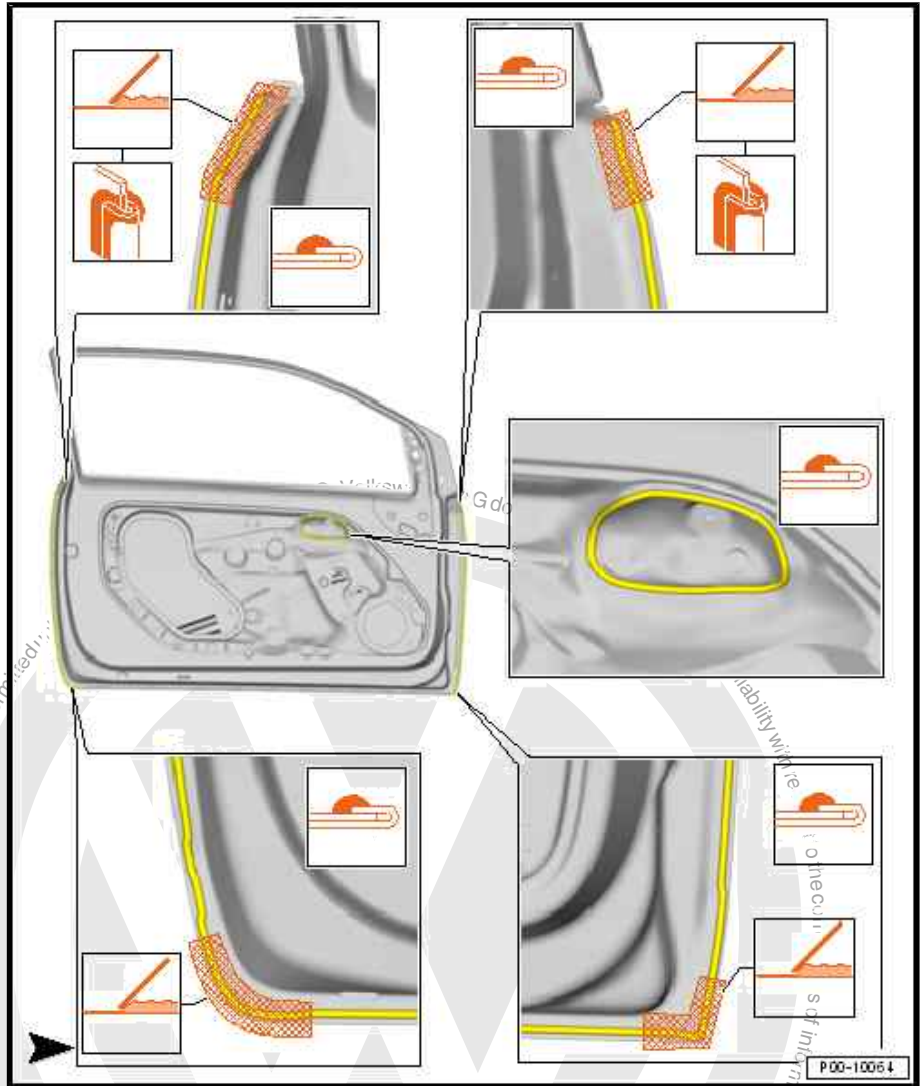

**i Note**

*When smoothing the sealant seam, ensure that the sheet metal edges which are to be protected are not exposed. The metal must be covered with a sufficiently thick layer of PVC so that the groove in the folded seam remains closed.*

**Seam seals, front door of 4-door**

Illustration shows left side. The right side is the mirror image.



### - Fine seam sealing

- ❑ Fine seam seals require that the sealant extend at least 3 mm from the seam in each direction and must have a thickness of 1.5 mm to 2 mm.

### - Smoothing seals

- ❑ Sealant in the marked areas must be smoothed following application.

### - Sealing the folded seam groove

- ❑ The marked areas must be closed following application of sealant to the folded seam groove.

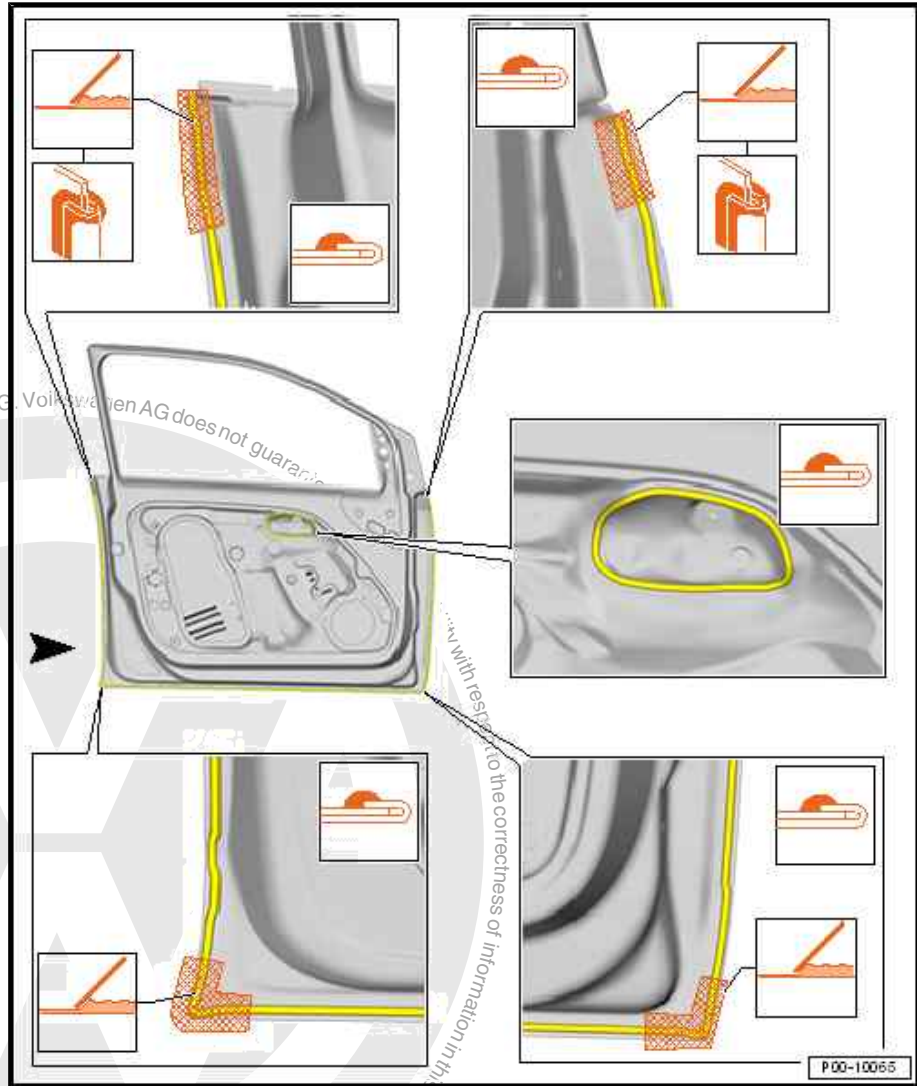

### Note

*When smoothing the sealant seam, ensure that the sheet metal edges which are to be protected are not exposed. The metal must be covered with a sufficiently thick layer of PVC so that the groove in the folded seam remains closed.*

### Seam seals, rear door of 4-door

Illustration shows left side. The right side is the mirror image.





**- Fine seam sealing**

- ❑ Fine seam seals require that the sealant extend at least 3 mm from the seam in each direction and must have a thickness of 1.5 mm to 2 mm.

**- Smoothing seals**

- ❑ Sealant in the marked areas must be smoothed following application.

**- Sealing the folded seam groove**

- ❑ The marked areas must be closed following application of sealant to the folded seam groove.

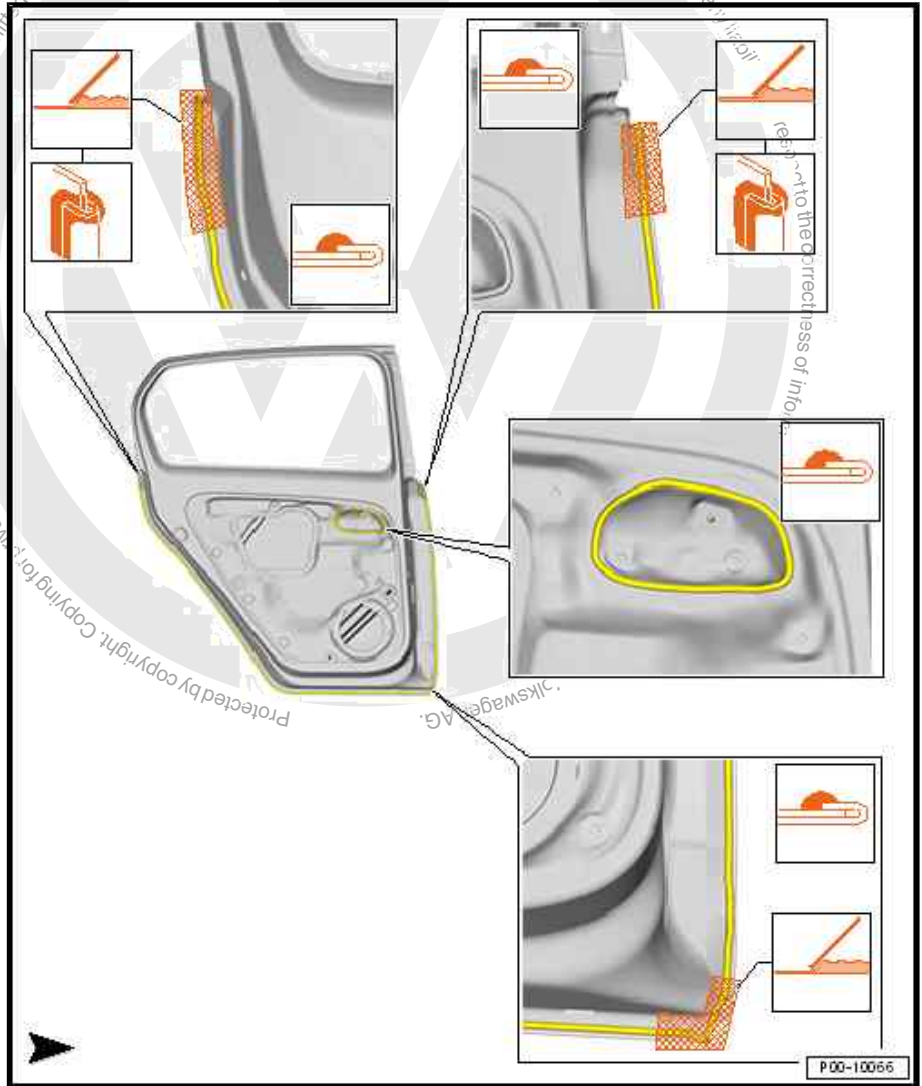

**i Note**

*When smoothing the sealant seam, ensure that the sheet metal edges which are to be protected are not exposed. The metal must be covered with a sufficiently thick layer of PVC so that the groove in the folded seam remains closed.*

**Seam seals, exterior of rear door, 4-door models**

Illustration shows left side. The right side is the mirror image.



**- Fine seam sealing**

- ❑ Fine seam seals require that the sealant extend at least 3 mm from the seam in each direction and must have a thickness of 1.5 mm to 2 mm.

**- Smoothing seals**

- ❑ Sealant in the marked areas must be smoothed following application

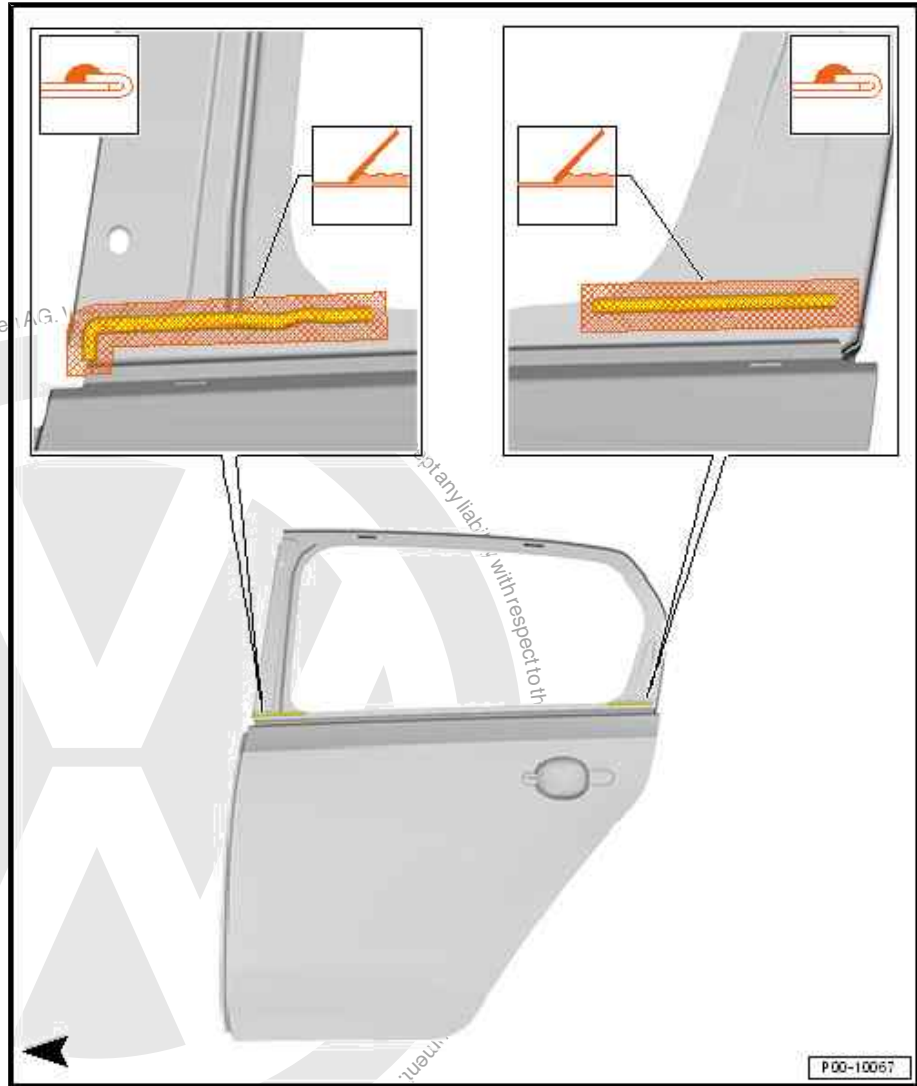

**Note**

*When smoothing the sealant seam, ensure that the sheet metal edges which are to be protected are not exposed. The metal must be covered with a sufficiently thick layer of PVC.*



## 5.3 Seam seals, rear body

### Note

- ◆ *When performing repair work, the seam sealing should be restored to match the original appearance and layer thickness.*
- ◆ *To avoid damage or faulty operation, brush seam seals smooth near parts which must be attached.*
- ◆ *Water drainage holes must remain clear.*
- ◆ *All threaded studs and welded nuts with metric threads as well as all other studs and contact surfaces for assembly must be functional following the extent of the sealing work.*
- ◆ *Sealant must never be applied to bare substrates. Substrates must always be surfaced first.*

### Seam seals on rear cross panel, up to model year 2016

Illustration shows left side. The right side is the mirror image.

#### - Fine seam sealing

- Fine seam seals require that the sealant extend at least 3 mm from the seam in each direction and must have a thickness of 1.5 mm to 2 mm.

#### - Smoothing seals

- Sealant in the marked areas must be smoothed following application.

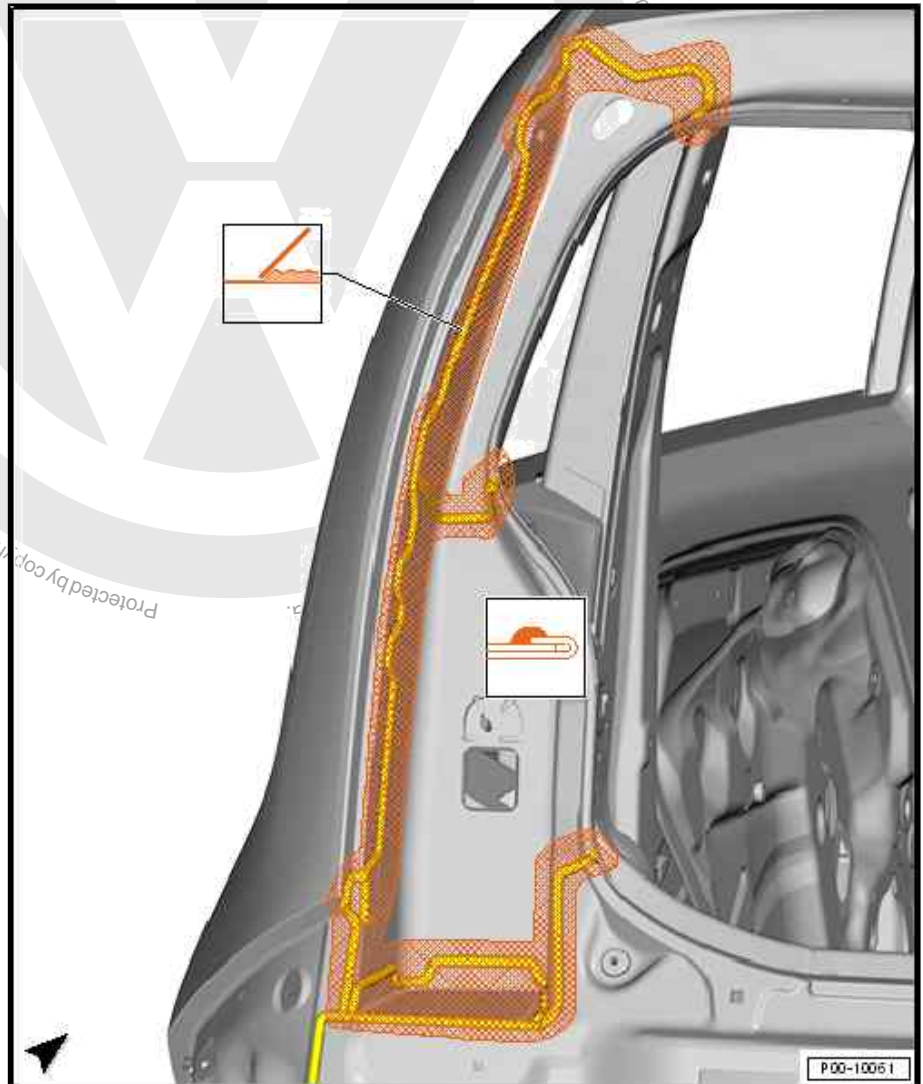



**i** Note

*When smoothing the sealant seam, ensure that the sheet metal edges which are to be protected are not exposed. The metal must be covered with a sufficiently thick layer of PVC.*

**Seam seals on rear cross panel, as of model year 2017**

Illustration shows left side. The right side is the mirror image.

**- Fine seam sealing**

- ❑ Fine seam seals require that the sealant extend at least 3 mm from the seam in each direction and must have a thickness of 1.5 mm to 2 mm.

**- Smoothing seals**

- ❑ Sealant in the marked areas must be smoothed following application.

**- Brushing seals**

- ❑ Sealant in the marked areas must be brushed following application.

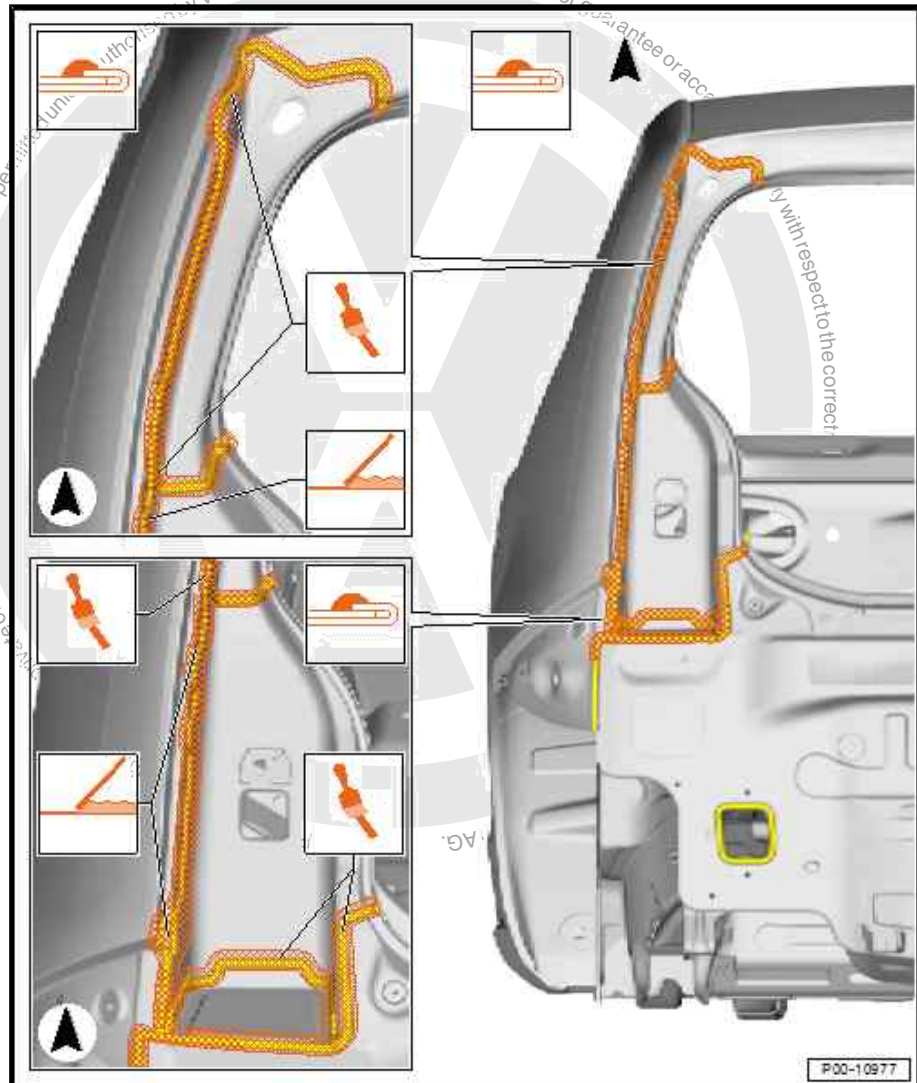

**i** Note

*When smoothing or brushing the sealant seam, ensure that the sheet metal edges which are to be protected are not exposed. The metal must be covered with a sufficiently thick layer of PVC.*

**Seam seals, rear left wheel housing**



**- Fine seam sealing**

- ❑ Fine seam seals require that the sealant extend at least 3 mm from the seam in each direction and must have a thickness of 1.5 mm to 2 mm.

**- Coarse seam sealing**

- ❑ Coarse seam seals require that the sealant be applied at least 8 mm wide and 2 mm high.

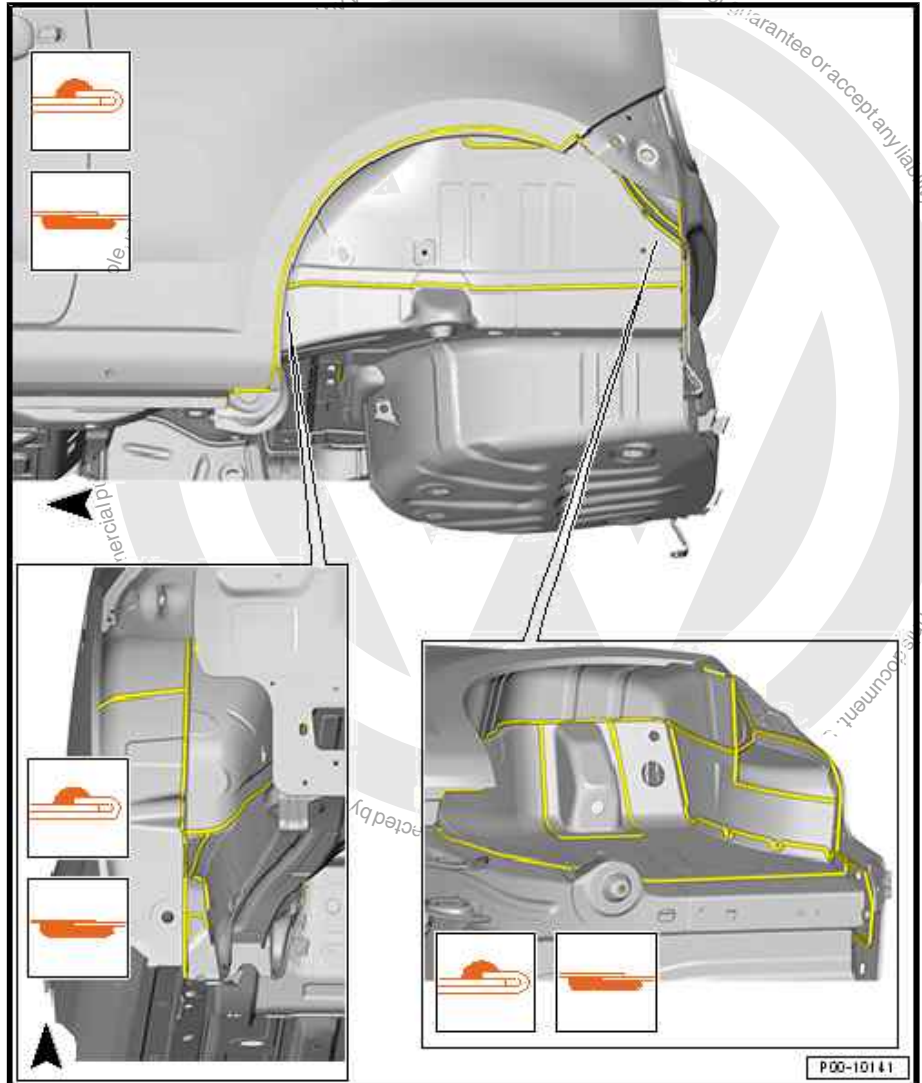

Seam seals, right wheel housing



**- Fine seam sealing**

- ❑ Fine seam seals require that the sealant extend at least 3 mm from the seam in each direction and must have a thickness of 1.5 mm to 2 mm.

**- Coarse seam sealing**

- ❑ Coarse seam seals require that the sealant be applied at least 8 mm wide and 2 mm high.

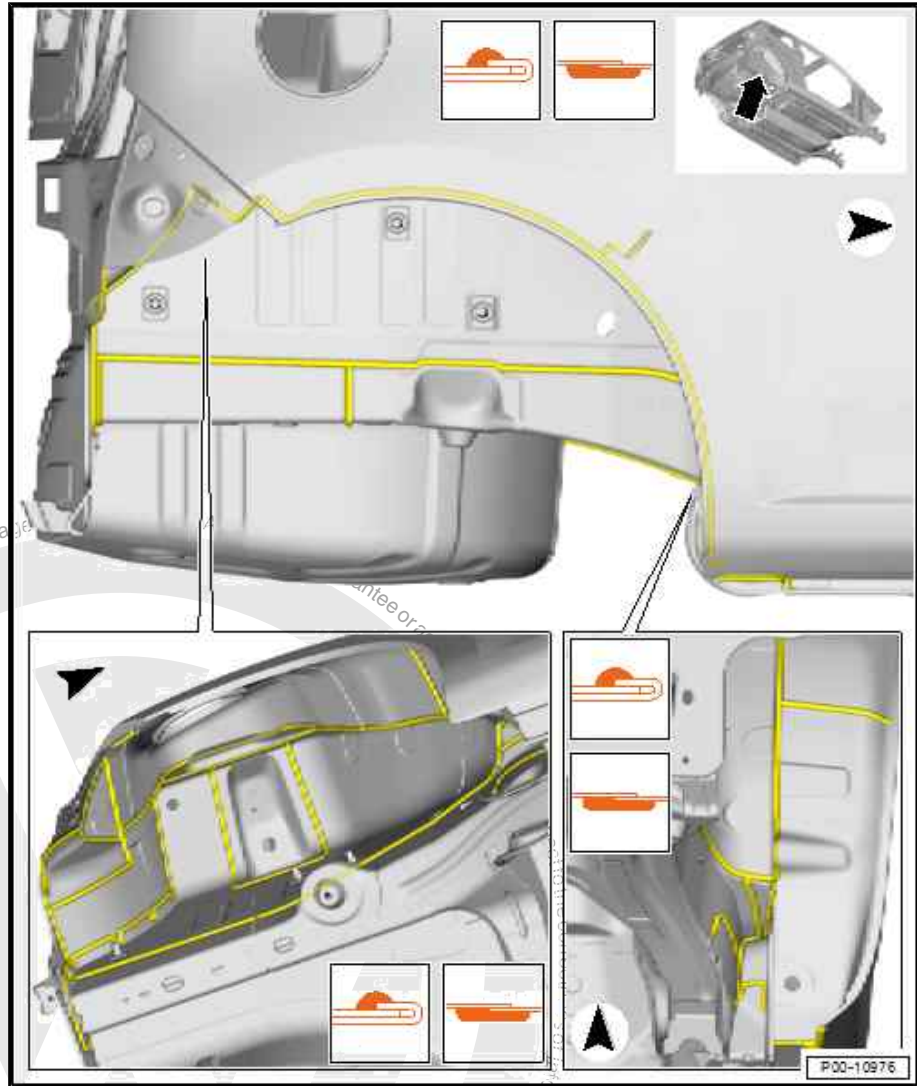

**Seam seals, rear lid**

Illustration shows left side. The right side is the mirror image.



**- Fine seam sealing**

- Fine seam seals require that the sealant extend at least 3 mm from the seam in each direction and must have a thickness of 1.5 mm to 2 mm.

**- Smoothing seals**

- Sealant in the marked areas must be smoothed following application.

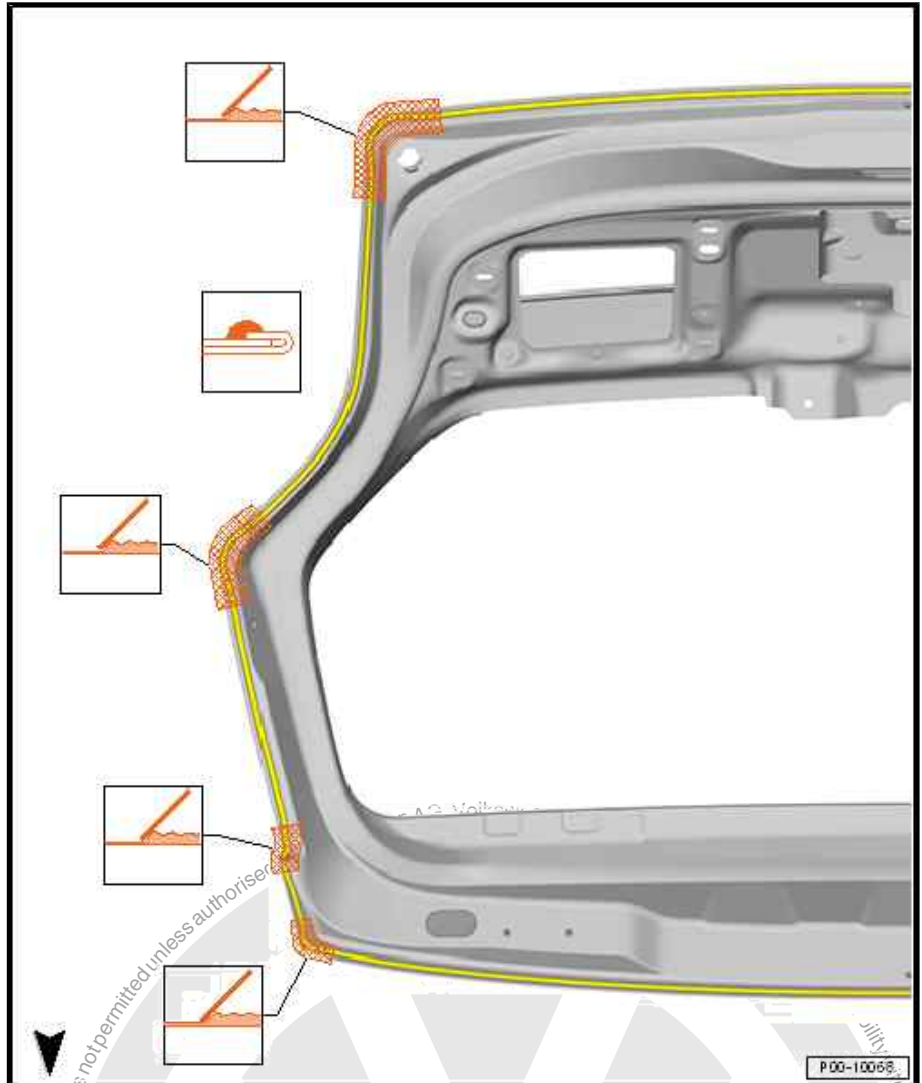

**Note**

*When smoothing the sealant seam, ensure that the sheet metal edges which are to be protected are not exposed. The metal must be covered with a sufficiently thick layer of PVC.*



## 6 Underseal

⇒ **"6.1 Underseal, body overview with differing layer thickness", page 68**

⇒ **"6.2 Underseal, protected areas", page 70**

### 6.1 Underseal, body overview with differing layer thickness



#### Note

- ◆ *Underseal (stone-chipping protection) applied during repair work must be identical in appearance and thickness to the original underseal.*
- ◆ *Water drainage holes must remain clear.*
- ◆ *All threaded studs and welded nuts with metric threads as well as all other studs and contact surfaces for assembly must be functional following the application of the underseal.*

#### Underseal, overview up to model year 2016

##### a - Underseal

- Coat thickness: 0.3 mm

##### b - Underseal

- Coat thickness: 0.7 mm

##### c - Underseal

- Coat thickness: 0.5 mm

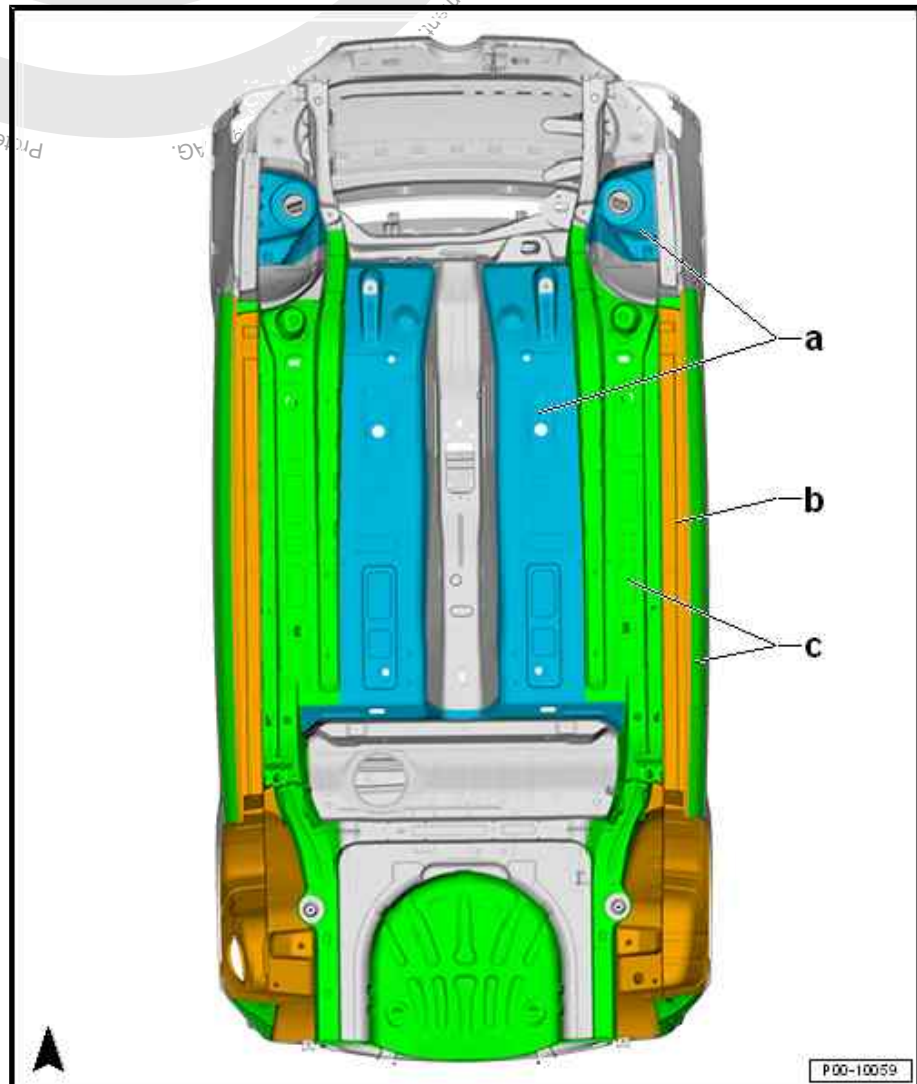

#### Underseal, overview as of model year 2017





**a - Underseal**

- Coat thickness: 0.3 mm

**b - Underseal**

- Coat thickness: 0.7 mm

**c - Underseal**

- Coat thickness: 0.5 mm

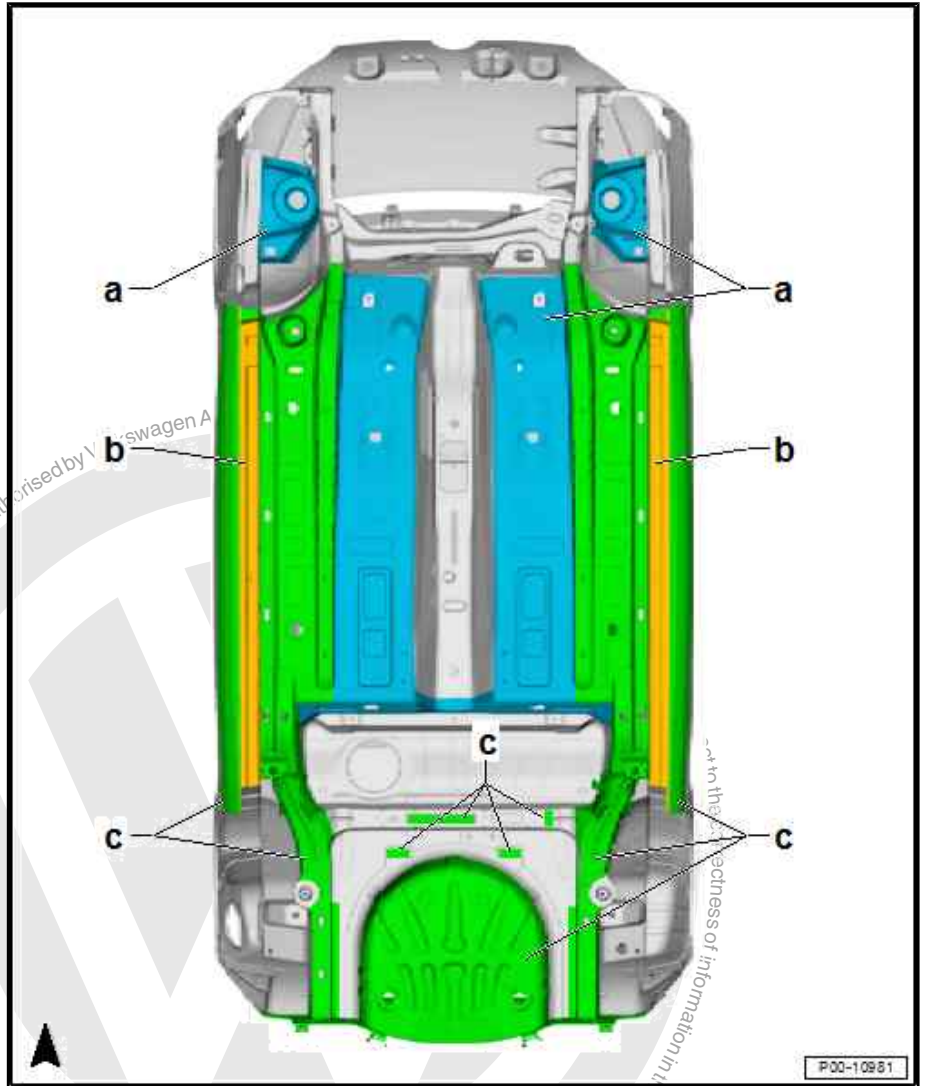

Underseal, overview as of model year 2017 (TSI)



**a - Underseal**

- Coat thickness: 0.3 mm

**b - Underseal**

- Coat thickness: 0.7 mm

**c - Underseal**

- Coat thickness: 0.5 mm

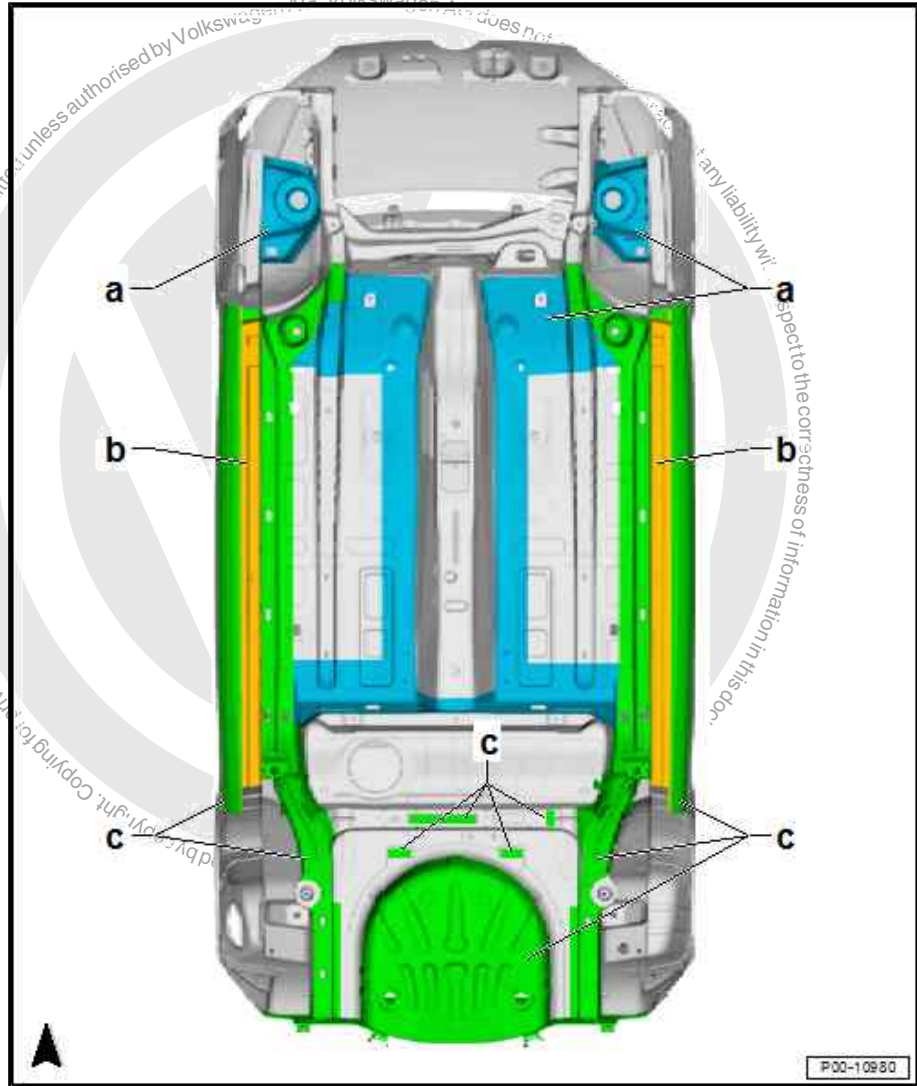

## 6.2 Underseal, protected areas



**Note**

- ◆ *Underseal (stone-chipping protection) applied during repair work must be identical in appearance and thickness to the original underseal.*
- ◆ *Water drainage holes must remain clear.*
- ◆ *All threaded studs and welded nuts with metric threads as well as all other studs and contact surfaces for assembly must be functional following the application of the underseal.*

Underseal, front wheel housing, as of model year 2017



**a - Underseal**

- ☐ Coat thickness: 0.3 mm

**c - Underseal**

- ☐ Coat thickness: 0.5 mm

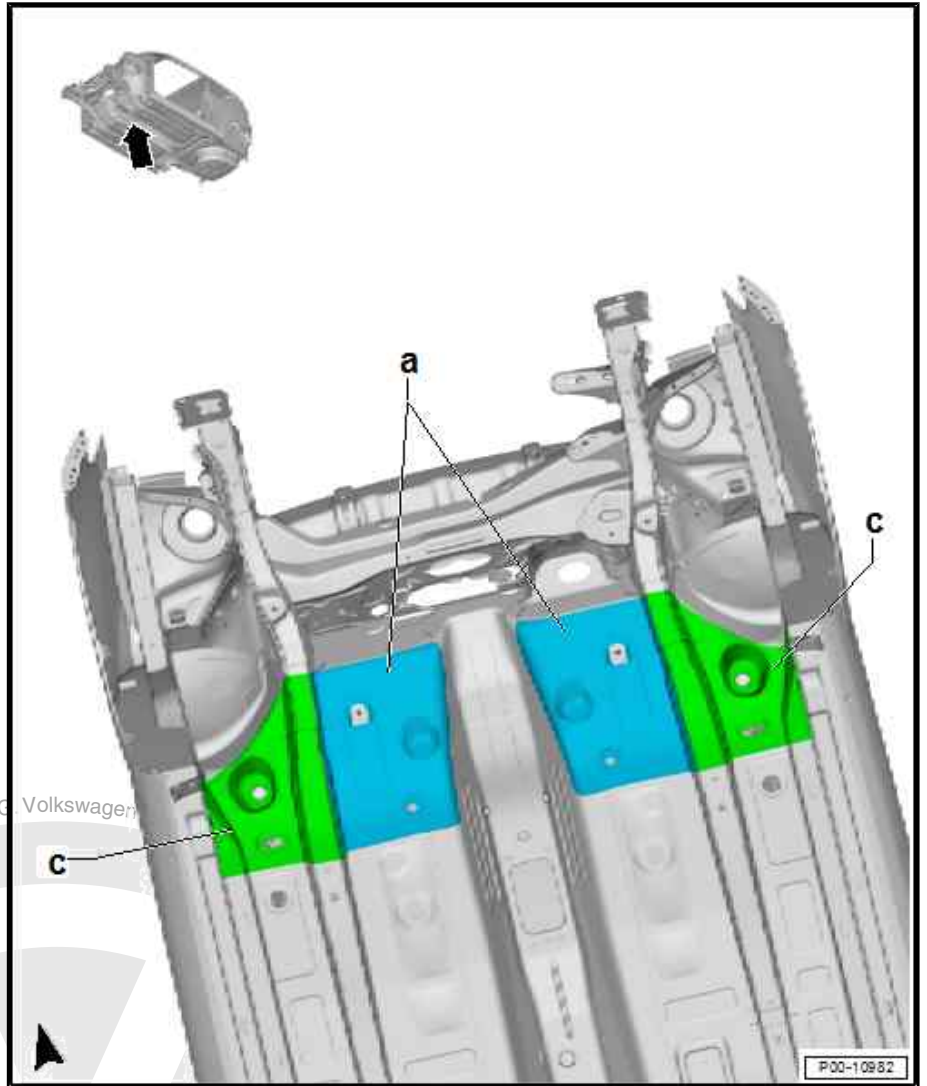

**Underseal, front wheel housing, as of model year 2017 (TSI)**

Protected by copyright. Copying for private or commercial purposes, in part or in whole, is not permitted unless authorised by Volkswagen AG. Volkswagen AG. respect to the correctness of information in this document. Copyright by Volkswagen AG.



**a - Underseal**

- Coat thickness: 0.3 mm

**c - Underseal**

- Coat thickness: 0.5 mm

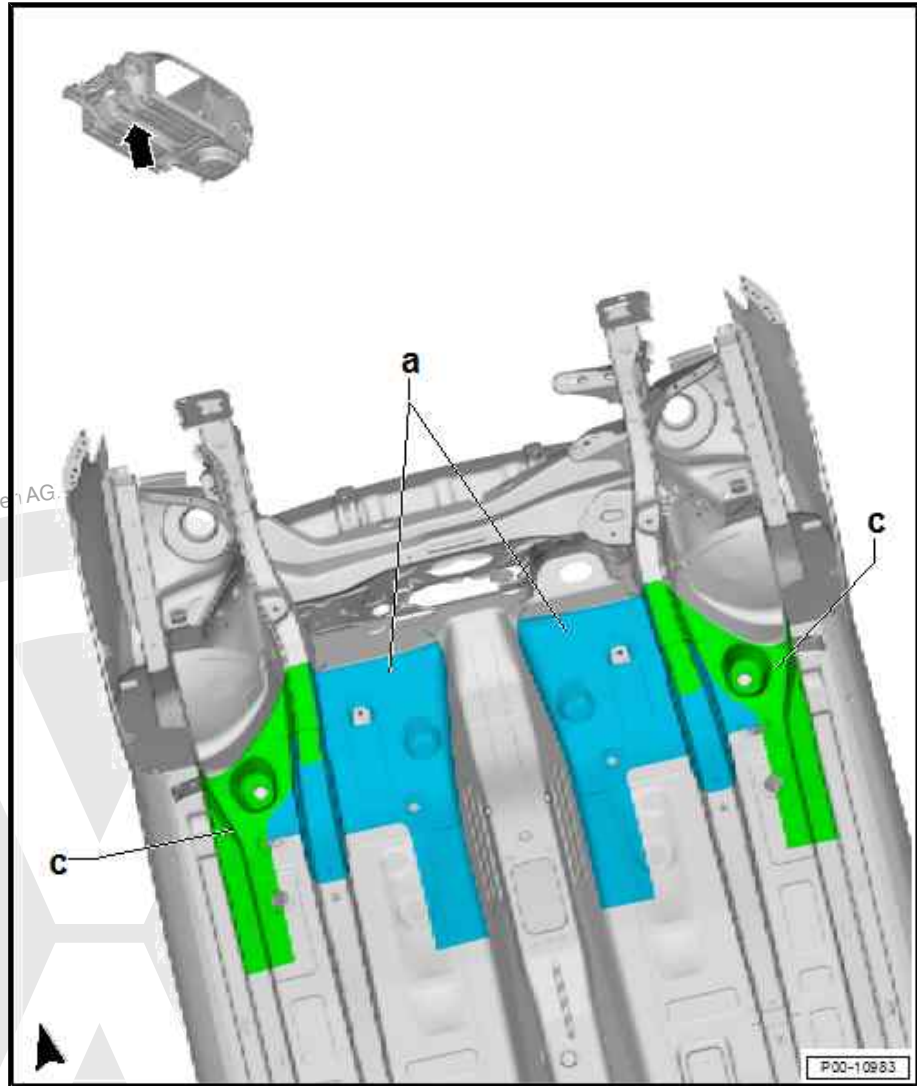

**Underseal at rear, up to model year 2016**

- ◆ Upper illustration shows a CNG-fuel vehicle
- ◆ Lower illustration shows a conventional-fuel vehicle



**c - Underseal**

- Coat thickness: 0.5 mm

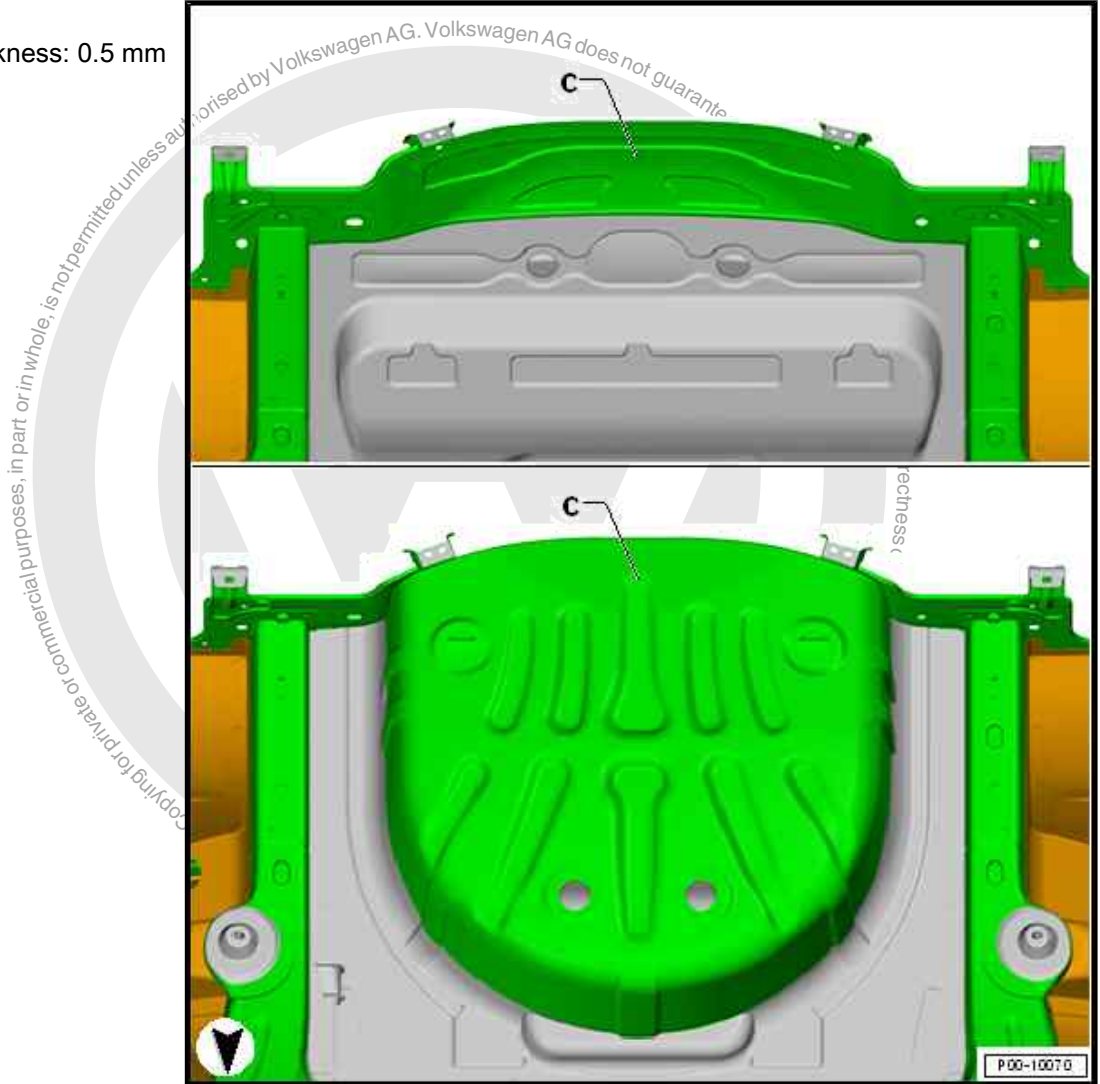

Underseal at rear, as of model year 2017



**a - Underseal**

- Coat thickness: 0.3 mm

**c - Underseal**

- Coat thickness: 0.5 mm

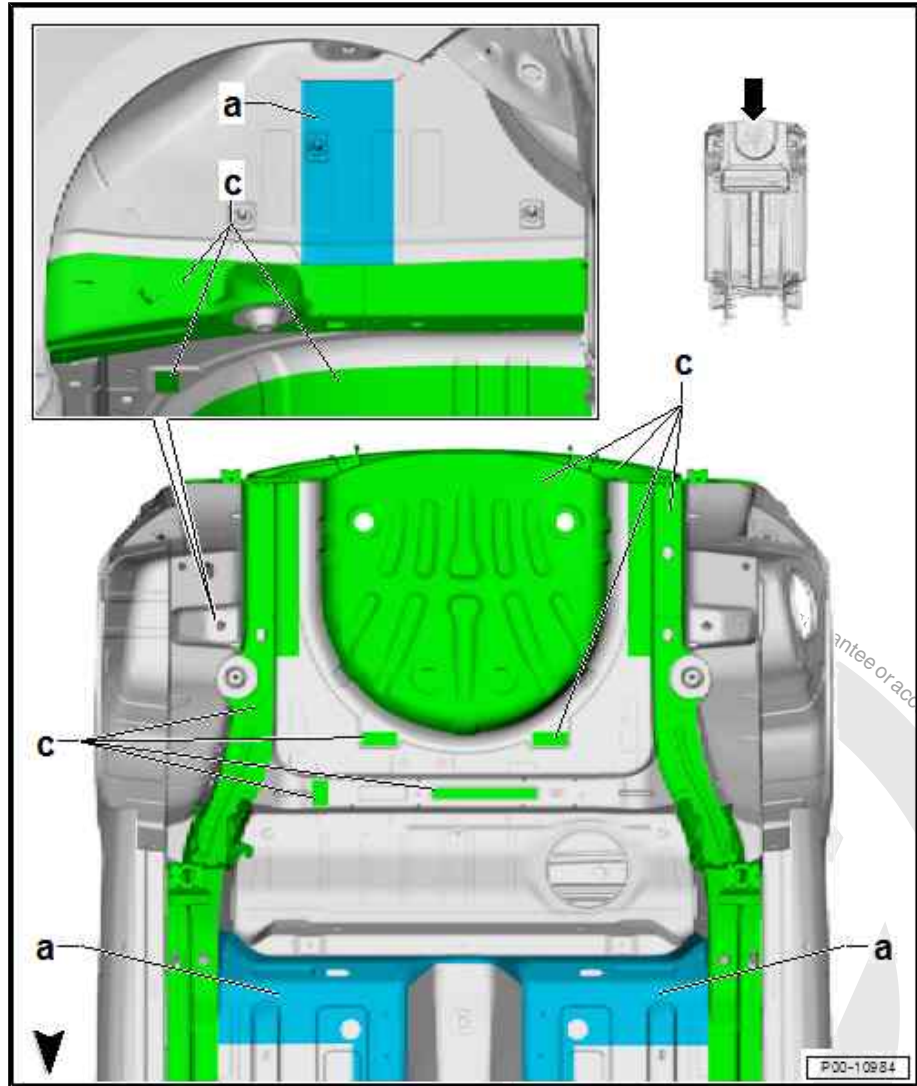

**Note**

- ◆ Underseal (stone-chipping protection) applied during repair work must be identical in appearance and thickness to the original underseal.
- ◆ Water drainage holes must remain clear.
- ◆ All threaded studs and welded nuts with metric threads as well as all other studs and contact surfaces for assembly must be functional following the application of the underseal.

**Undercoating, front strut mounting reinforcement**

Illustration shows left side. The right side is the mirror image.



### a - Underseal

- Coat thickness: 0.3 mm

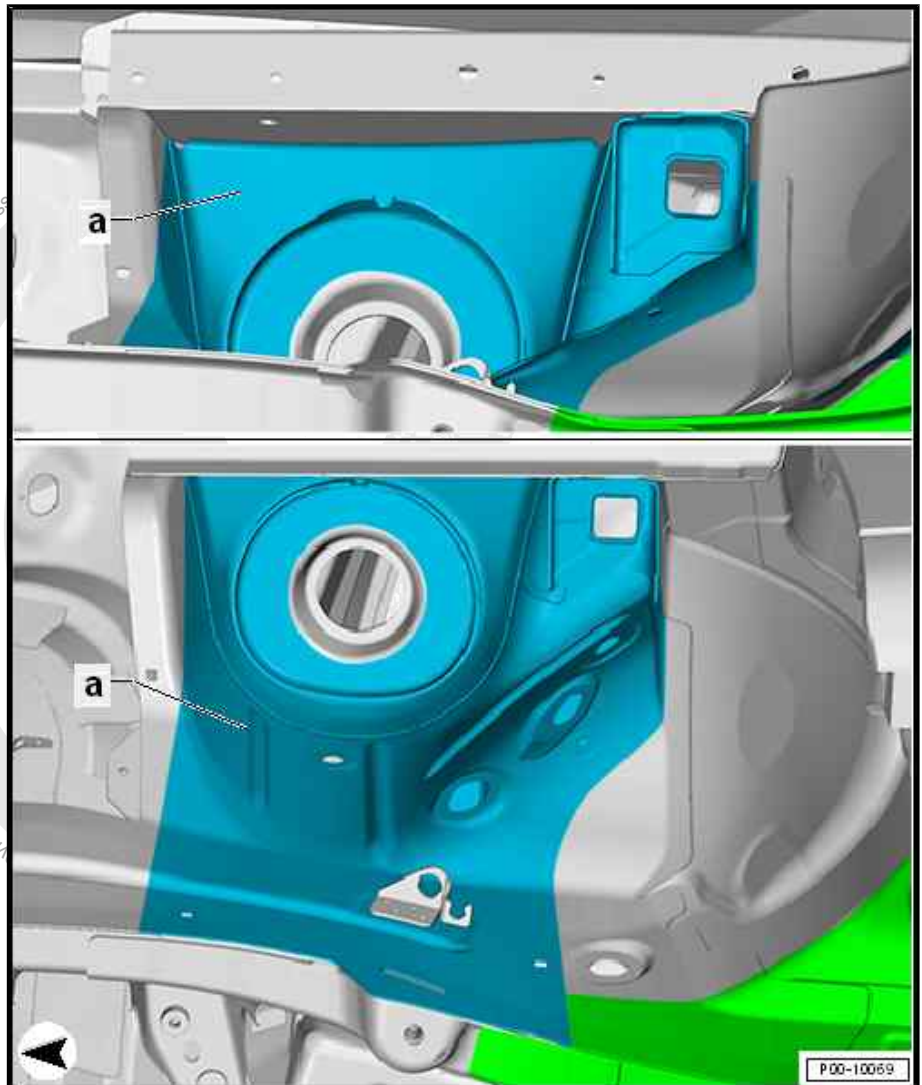

### Note

- ◆ Underseal (stone-chipping protection) applied during repair work must be identical in appearance and thickness to the original underseal.
- ◆ Water drainage holes must remain clear.
- ◆ All threaded studs and welded nuts with metric threads as well as all other studs and contact surfaces for assembly must be functional following the application of the underseal.

### Underseal, side member

Illustration shows left side. The right side is the mirror image.



**b - Underseal**

- Coat thickness: 0.7 mm

**c - Underseal**

- Coat thickness: 0.5 mm

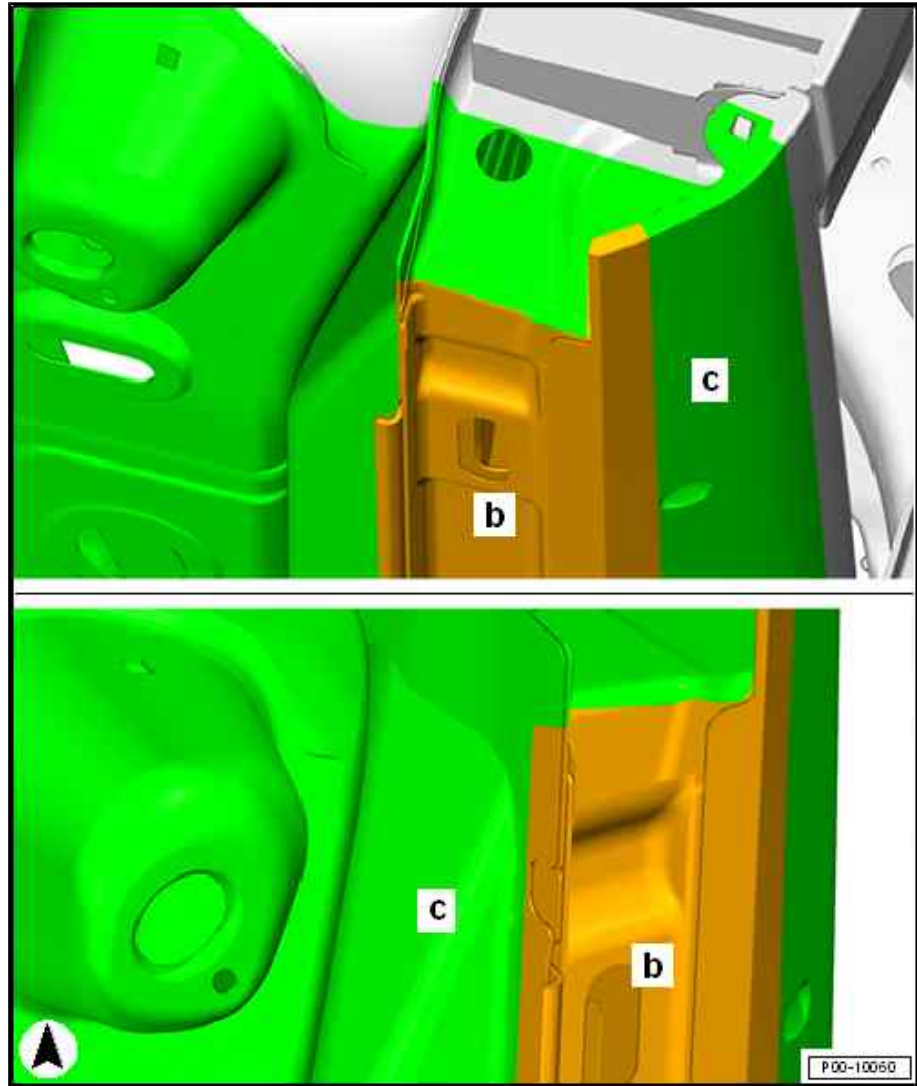

**Note**

- ◆ *Underseal (stone-chipping protection) applied during repair work must be identical in appearance and thickness to the original underseal.*
- ◆ *Water drainage holes must remain clear.*
- ◆ *All threaded studs and welded nuts with metric threads as well as all other studs and contact surfaces for assembly must be functional following the application of the underseal.*

**Underseal, side member, with sectional view**

Illustration shows left side. The right side is the mirror image.





**b - Underseal**

- Coat thickness: 0.7 mm

**c - Underseal**

- Coat thickness: 0.5 mm

**1 - Side panel, exterior**

**2 - Side member, interior**

**- Dimension -x-**

- UP: leave 10 mm surface free of PVC

**- Dimension -y-**

- Cross Up: leave 37-45 mm surface free of PVC

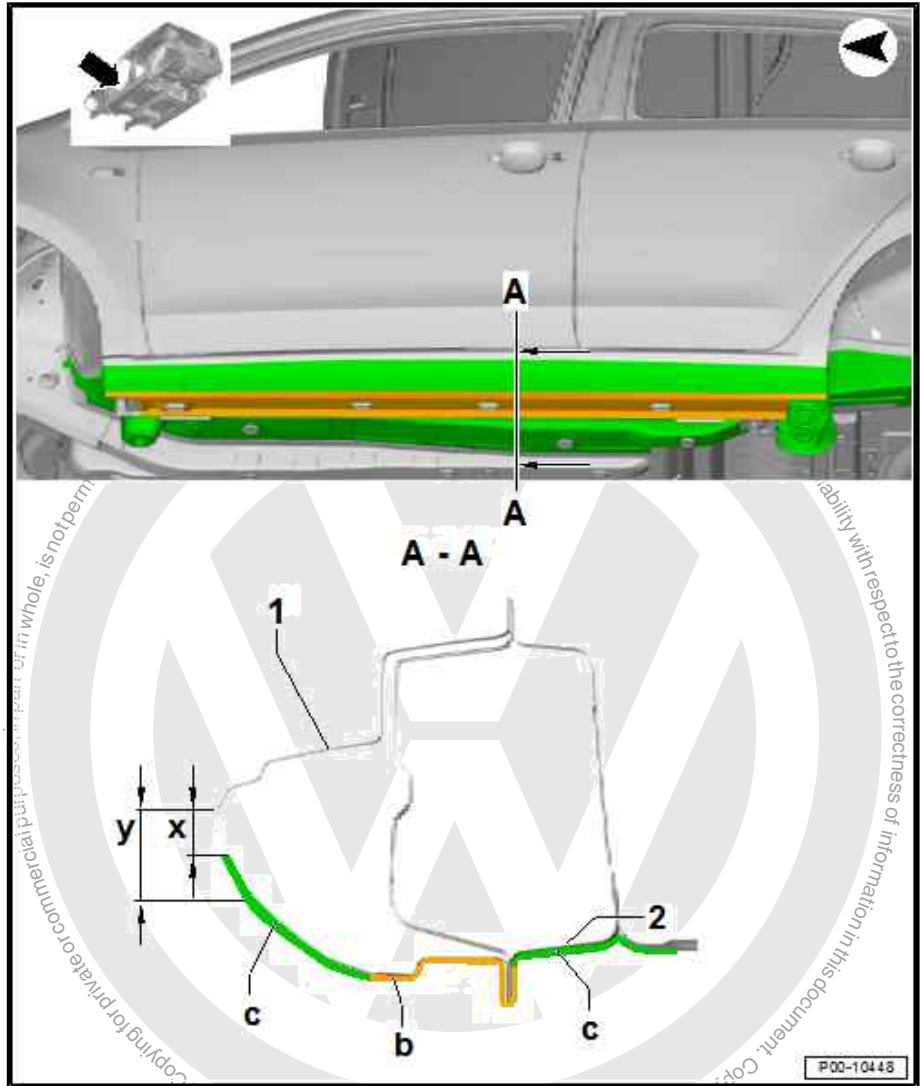



## 7 Cavity sealing

⇒ [“7.1 Cavity sealing, body - overview”, page 78](#)

⇒ [“7.2 Cavity sealing, front body”, page 78](#)

⇒ [“7.3 Cavity sealing, body – centre”, page 79](#)

⇒ [“7.4 Cavity sealing, rear body”, page 81](#)

### 7.1 Cavity sealing, body - overview



Note

*The indicated areas have been treated with cavity sealant and must be resealed following repairs.*

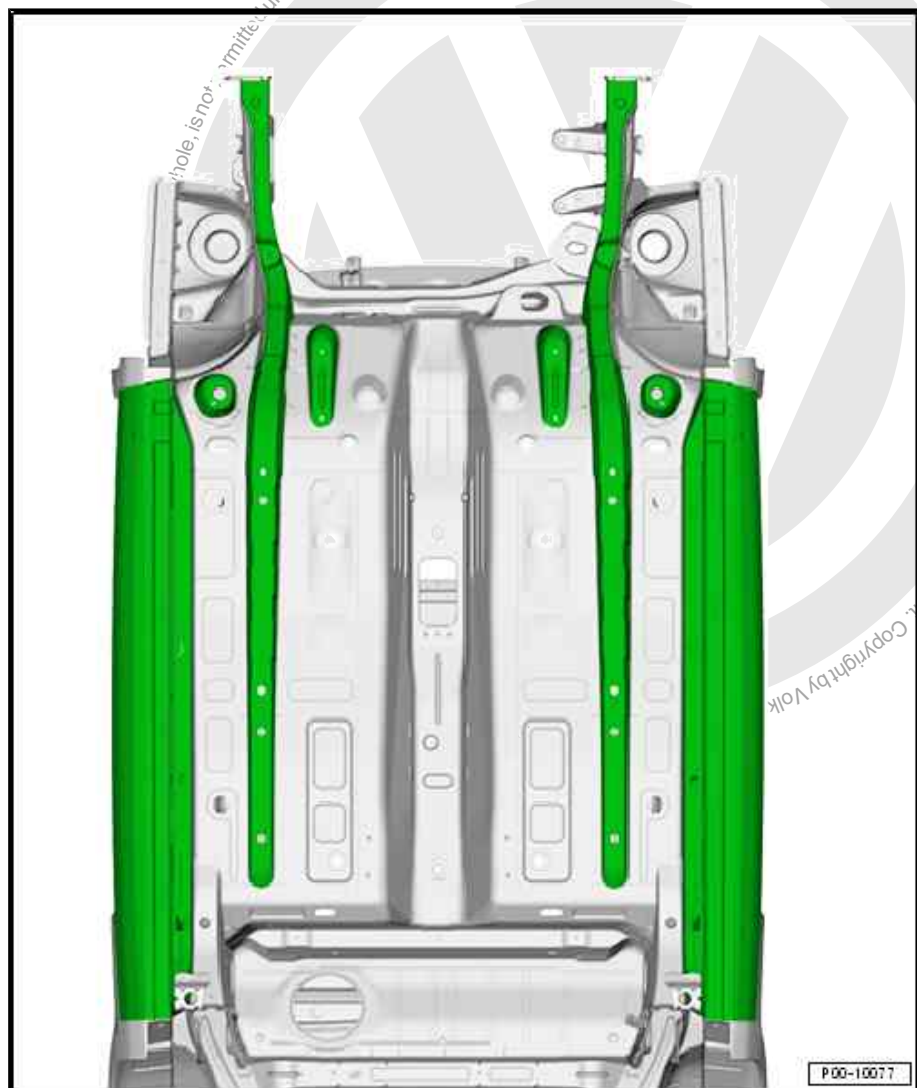

### 7.2 Cavity sealing, front body



Note

*The indicated areas have been treated with cavity sealant and must be resealed following repairs.*



### Cavity sealing, front body

Illustration shows left side. The right side is the mirror image.

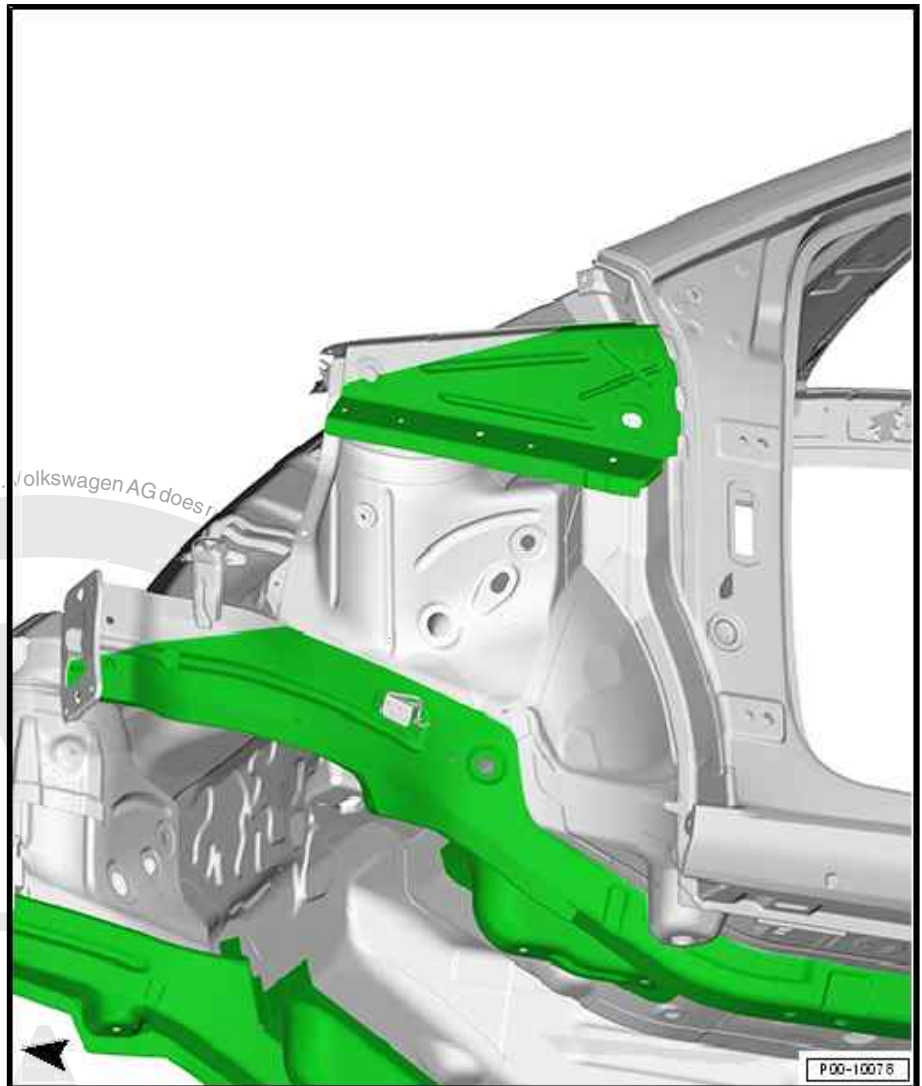

### 7.3 Cavity sealing, body – centre



#### Note

*The indicated areas have been treated with cavity sealant and must be resealed following repairs.*



### Cavity sealing, door of 2-door

Illustration shows left side. The right side is the mirror image.

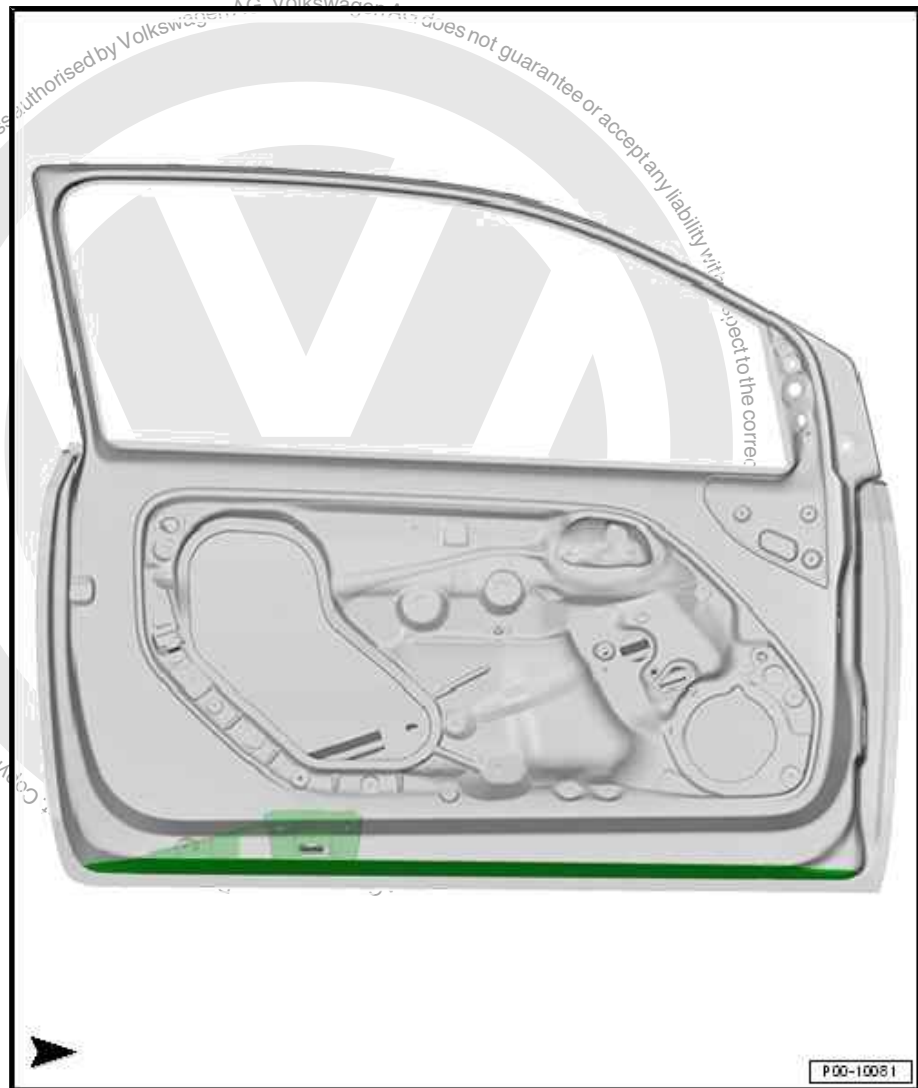

#### Note

*The indicated areas have been treated with cavity sealant and must be resealed following repairs.*

### Cavity sealing, door of 4-door

Illustration shows left side. The right side is the mirror image.

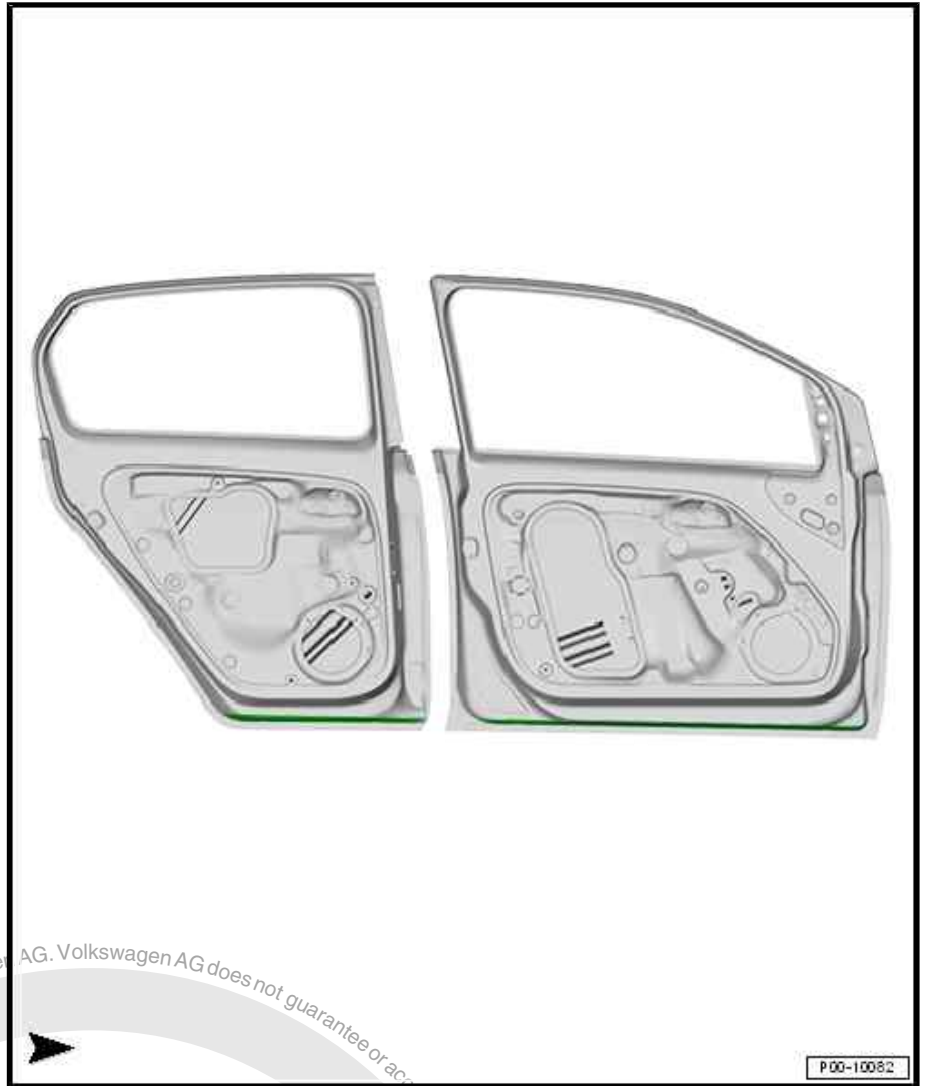

## 7.4 Cavity sealing, rear body



### Note

*The indicated areas have been treated with cavity sealant and must be resealed following repairs.*

### Cavity sealing, spare wheel well

Upper illustration shows a CNG-fuel vehicle



Lower illustration shows a conventional-fuel vehicle

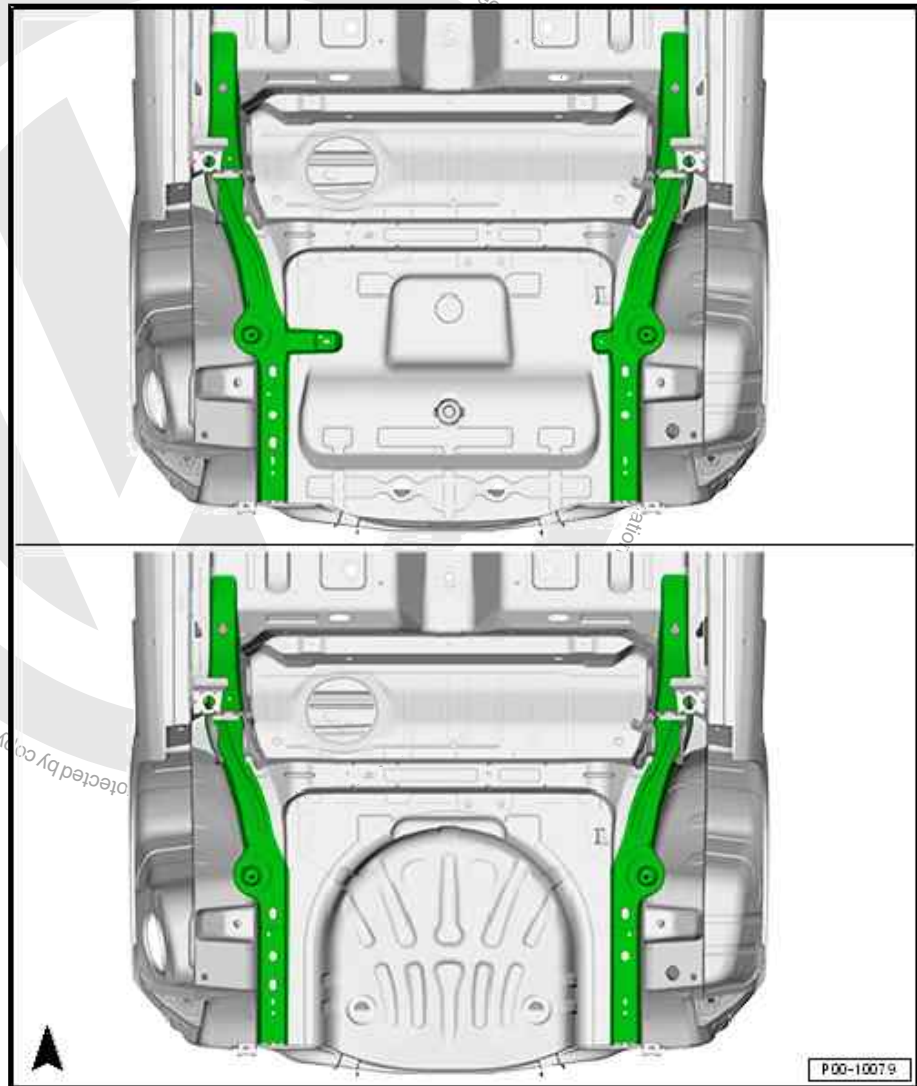

**Note**

*The indicated areas have been treated with cavity sealant and must be resealed following repairs.*

**Cavity sealing, side panel and wheel housing, all around on inside, and rear longitudinal member**

Illustration shows left side. The right side is the mirror image.



- Dimension -a-

□ 10 mm

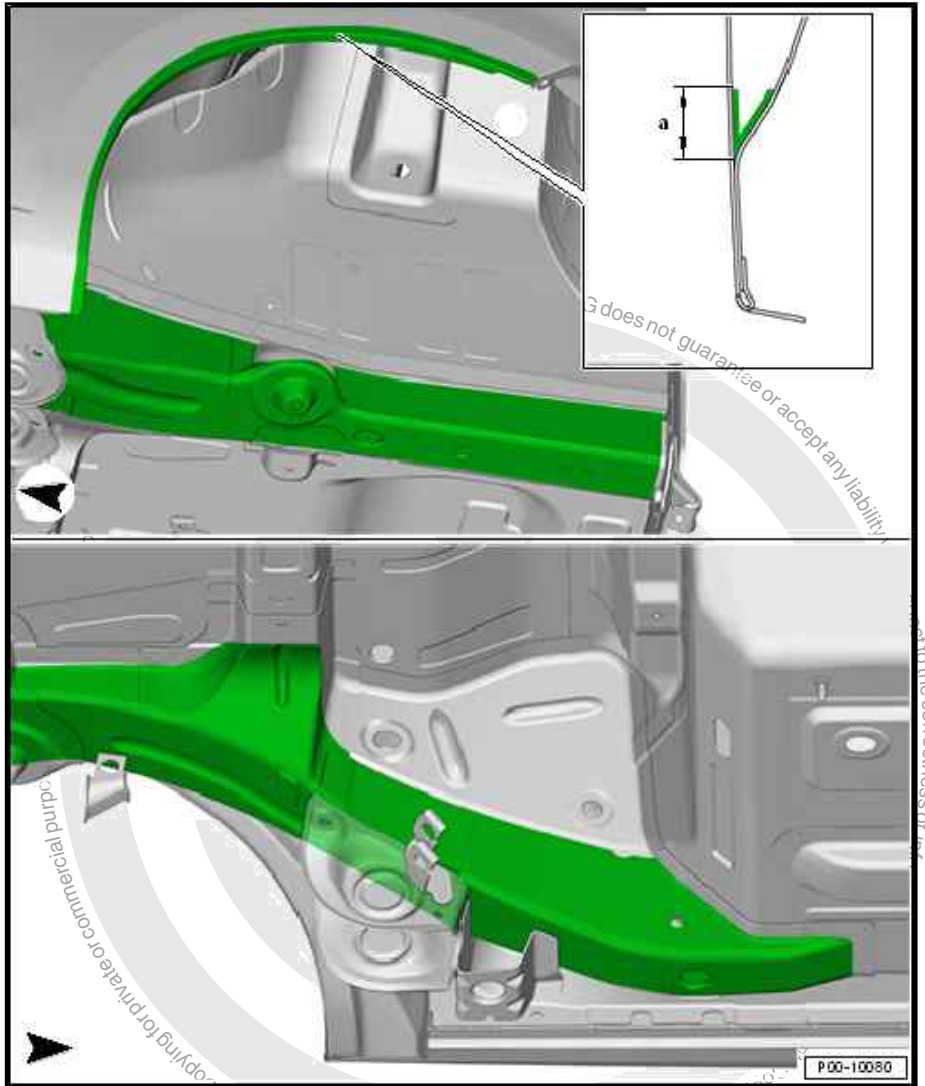



## 8 Contrasting colours

⇒ ["8.1 Contrasting colours Crossup", page 84](#)

⇒ ["8.2 Contrasting colours Cheerup", page 85](#)

⇒ ["8.3 Contrasting colours Grooveup", page 86](#)

⇒ ["8.4 Contrasting colours Cupup", page 87](#)

⇒ ["8.6 Contrasting colours, roof", page 89](#)

### 8.1 Contrasting colours »Cross«up

Contrasting colours »Cross«up

1 - Mirror cover left and right.

Colour: L-M7W Meteor Grey

2 - Front and rear bumper trim

- Colour: L-M7W Meteor Grey + matt clear coat

3 - Underneath front and back bumper

- Colour: L- L-M7W Meteor Grey + matt clear coat

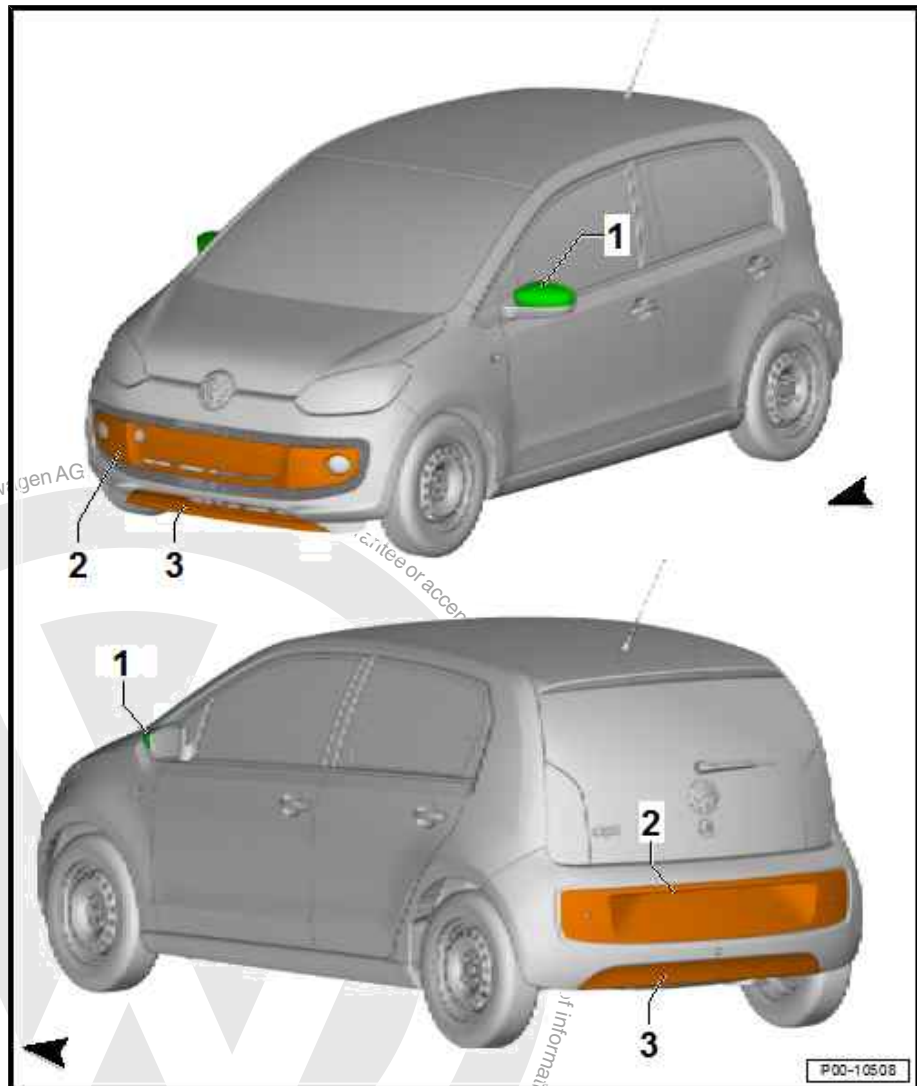





## 8.2 Contrasting colours »Cheer«up

Contrasting colours »Cheer«up

### 1 - Mirror cover left and right.

Colour: L-BJ8 Galvano Grey

### 2 - Protective side moulding left and right

Colour: L-BJ8 Galvano Grey

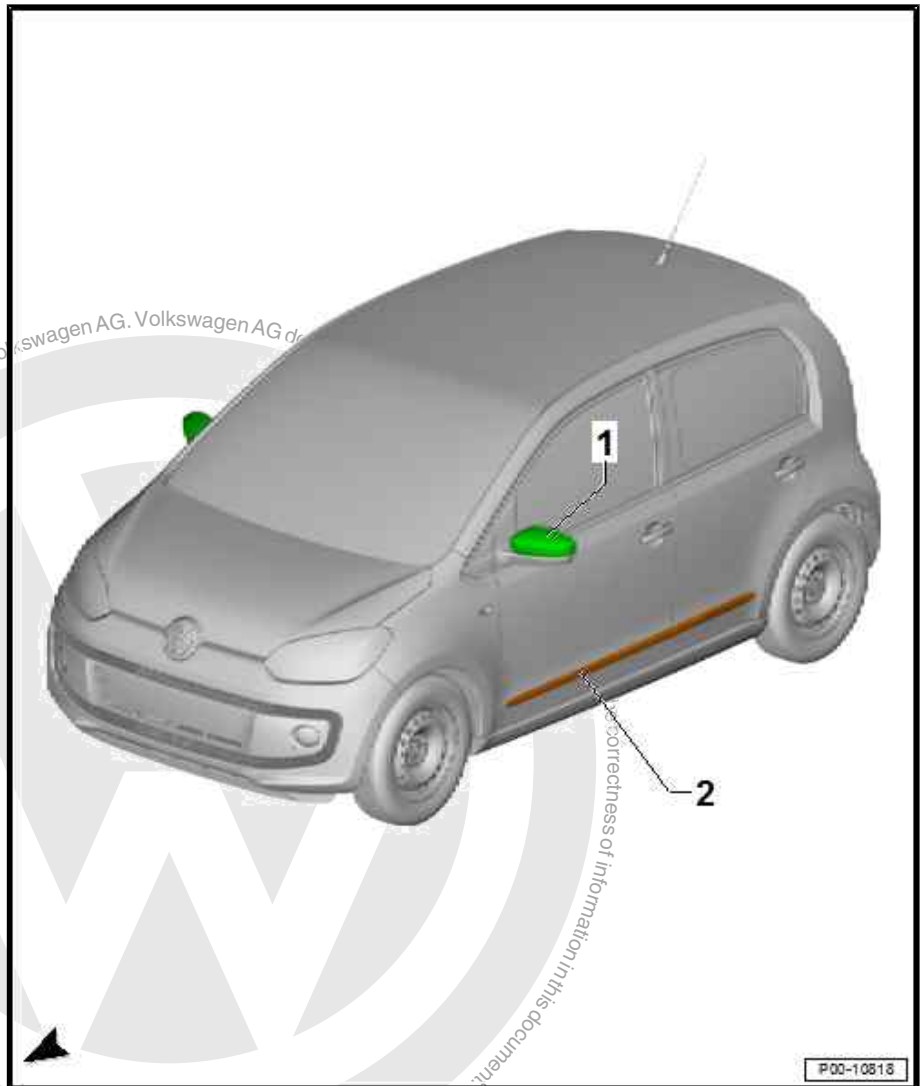



### 8.3 Contrasting colours »Groove«up

Contrasting colours »Groove«up

1 - Mirror cover left and right.

Colour: L-041 Black

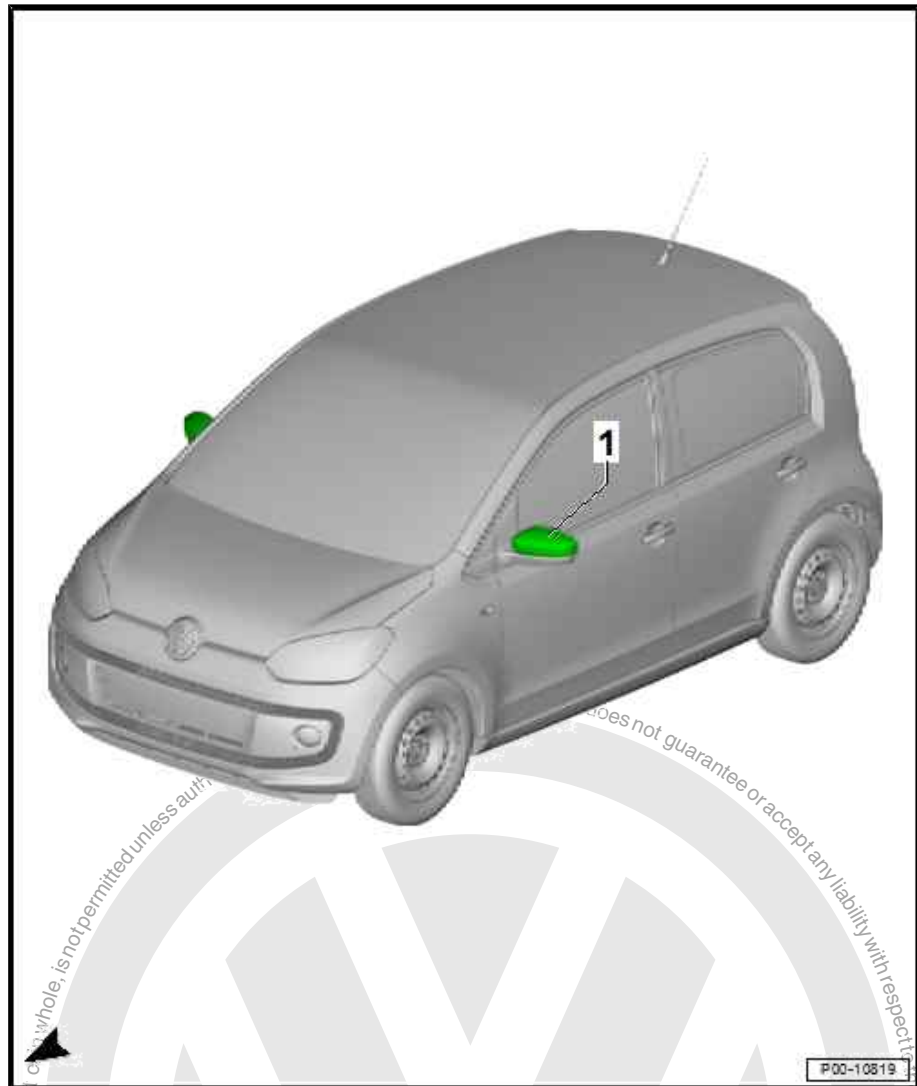



## 8.4 Contrasting colours »Cup«up

Contrasting colours »Cup«up

**1 - Mirror cover left and right.**

Colour: L-041 Black

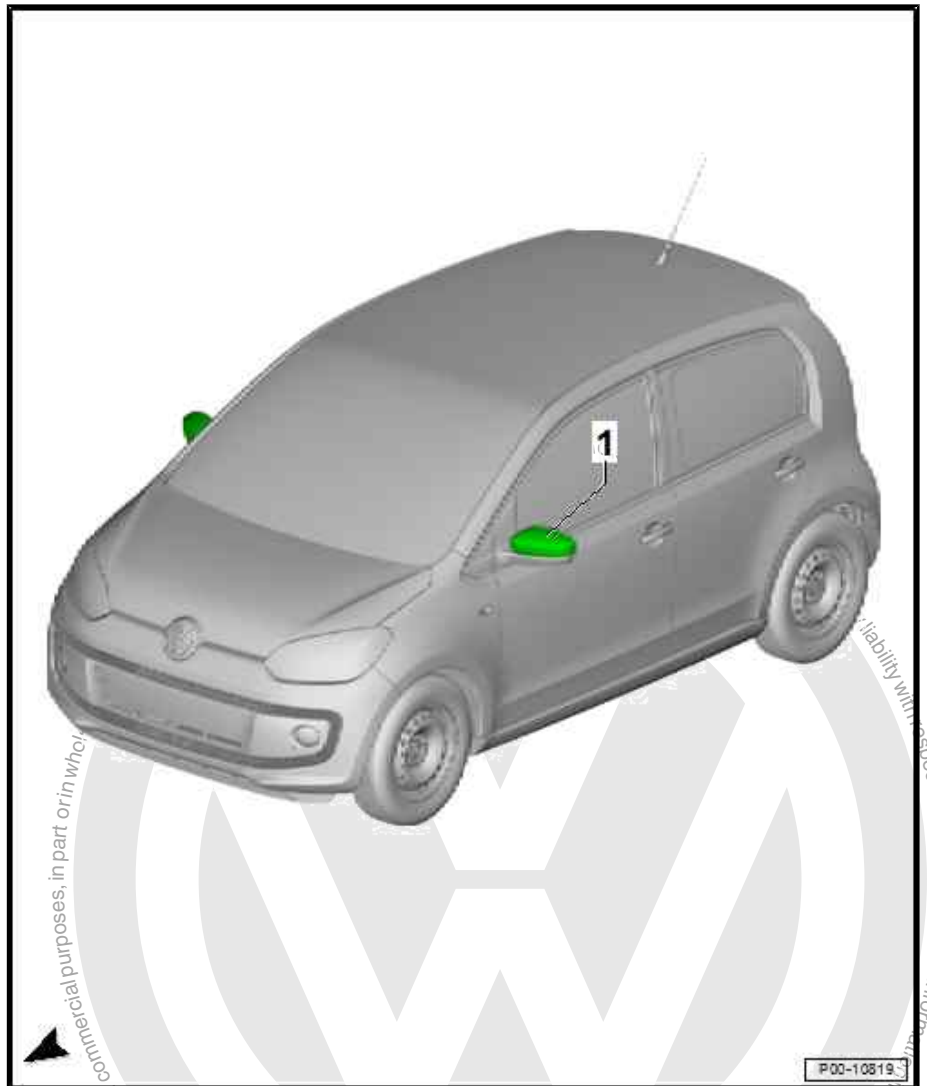

commercial purposes, in part or in whole.

Protected by copyright. Copying for private

Protected by copyright. Copying for private

Protected by copyright. Copying for private

liability with respect to the correctness of information.



## 8.5 Contrasting colours »Street«up

### Contrasting colours »Street«up

#### 1 - Mirror cover left and right.

Colour: L-A7W Light Silver, if the exterior of the entire vehicle is painted in the following colours: L-C9X Black Pearl, L-0K1 White Pearl, L-C9A Pure White

Colour: L-041 Black, if the exterior of the entire vehicle is painted in the colour L-A7W Light Silver

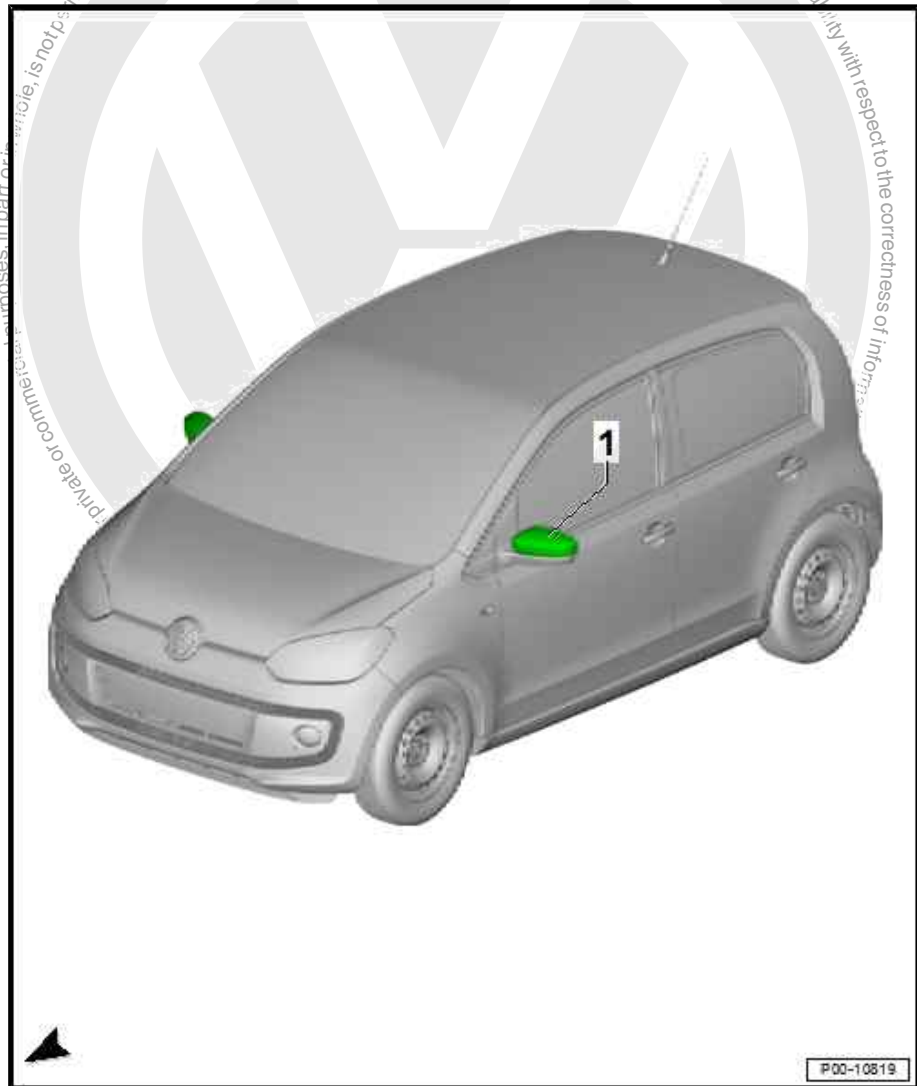



## 8.6 Contrasting colours, roof

### 1 - Entire vehicle

- Standard colour

### 2 - Roof

- Colour: black, solid »L-041«
- Colour: Candy White »L-B9A«
- Colour: Urano Grey »L-I7F«
- Dimension -x- = 5 mm
- Dimension -y- = 5 to 10 mm

